

# Fuel-PIT

## Fuel-Pit for Airports

- ENVIRONMENTAL FUEL PIT
- TESTED ACCORDING TO EN124 F900 NORM
- PIT HATCH COVER IN ALUMINIUM
- HOT DIPE GALVANIZED STEEL FRAME
- PIT BOX MADE OF STAINLESS STEEL
- OPENING DIAMETER 18"
- INTERNAL DIAMETER 23"
- ALUMINIUM TEAR PLATE

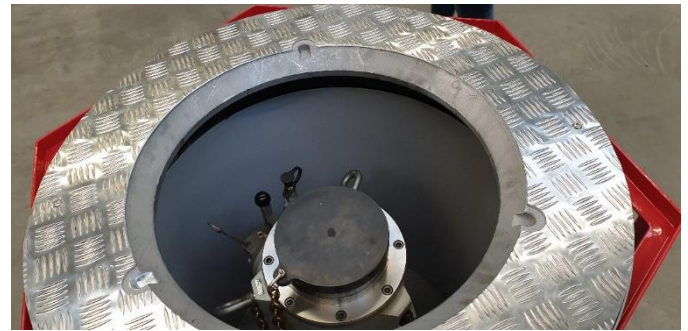
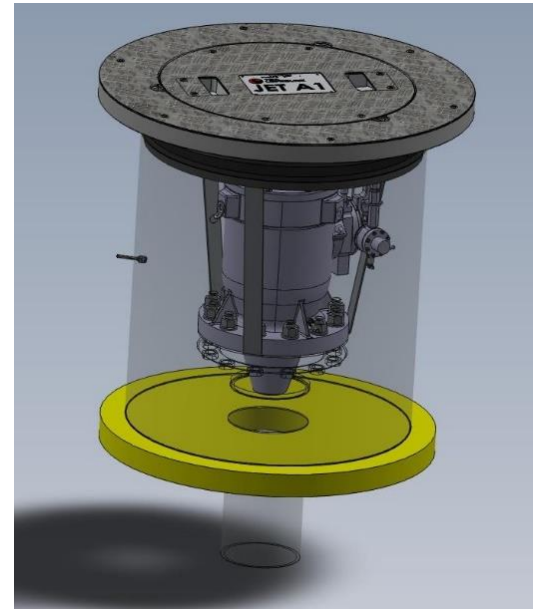

### FEATURES

- Hatch cover weight : 15 kg
- High Level seal for easy maintenance (high resistance to Jet A1)
- Comply with API 1584
- Double lining with 40 mm acceptable displacement in 3 directions



7 rue des Livraindières  
28100 DREUX - France  
☎ +33 2 37 51 41 72  
✉ +33 2 37 51 97 99  
info@tda-lefebure.com  
www.tda-lefebure.com