

**MUFLE**  
PASSION FOR DRAINAGE

**MufleDrain**  
INSTALLATION CATALOGUE

# WATER CONVEYING SYSTEMS





---

# Summary

Introduction .....	pg	4
MufleDrain .....	pg	8
• FLAT .....	pg	14
» Installation FLAT .....	pg	15
• EASY .....	pg	17
» Installation EASY .....	pg	18
• SKIP .....	pg	21
» Installation SKIP .....	pg	22
• VIP .....	pg	24
» Installation VIP .....	pg	25
• SMART .....	pg	28
» Installation SMART .....	pg	29
• SLOPE .....	pg	31
» Installation SLOPE .....	pg	32
• WING .....	pg	34
» Installation WING .....	pg	35
• PLUS .....	pg	40
» Installation PLUS .....	pg	41
• FUNNEL .....	pg	45
» Installation FUNNEL .....	pg	46

For further updates please check the site [www.mufle.com](http://www.mufle.com) periodically.

---

---

# Mufle carries the water anywhere



The fast and safe drainage of rain water has always been one of the biggest problems in man's history, especially with the current climatic changes which make it more and more important in terms of security.

To the rain water must be added all the liquids deriving from the industry which must be quickly removed and collected into the suitable purification plants.

**MufleSystem**, leader in the **linear drainage system in HD-PE, in stainless steel** and in the **punctual drainage**, is specialized in water conveying system towards collection lines or points and offers innovative solutions and designs for water drainage.

The drainage products of MufleSystem decrease the environmental impact and are certified according to high quality standards.

---

# Why to choose MufleSystem?

## Because MufleSystem means **SPEARHEAD:**

MufleSystem introduced the new system for linear water drainage in 1996 and obtained a great success still growing on up to nowadays, bringing a change into the old traditional system in concrete with starting the use of High Density Polyethylene not only in the Italian market but also in the European market.

With this new system in HD-PE we became during the recent years the market leader in the field of linear water drainage channels and for all dealers involved in this business activity.

## Because MufleSystem means **IMPROVEMENTS and UPDATES:**

As specialized manufacturer in the linear drainage channels sector, we are not afraid of improvement, we think on the contrary that it is necessary and is implied in the products development.

Improvement means innovation and market leadership and this is the reason why it is very important for us, even if it requires huge investments in terms of financial resources and research.

The catalogue restyling introduces the new FUNNEL system for wide application areas, the SLOPE products with the innovative

fixing system and the dimensions 150/40 and 200/40 for the models EASY, VIP and WING, showing our attention to novelties and to our customers requirements.

## Because MufleSystem means **SAFETY:**

Your safety is a very important value especially for our company and for the industrial sector where we are working. For this reason we choose to test each product and each organization/ production procedure by the specialized institute IGQ (Institute Quality Guarantee) in order to obtain the certification for your guarantee.

## Because MufleSystem means **TEAM WORK:**

Nowadays MufleSystem has a sale network comprising 60 agencies all over the Italian territory. Its participation to all the most important Exhibitions abroad has increased its products distribution and export sales, establishing its own representative offices in all the European Union countries.



# The Mission

## THE MISSION

Our company identity has been created on the experience and professionalism of our people and allows us to achieve the leadership in product's innovation and draining systems for liquids convey, mainly for meteoric and industrial waters.

The careful company management and the continuous analysis of markets' and Clients' increase the value of every project and ensure a constant capital return to the shareholders but also guarantee a fair and consistent relationship with all our business partners.

## THE VISION

In order to become a leader company both for clients and competitors, MufleSystem srl pursues to reach a sustainable and profitable market niche through a constant products' and services' innovation.



# Corporate certifications

## CERTIFICATION ISO 9001 : 2008

MufleSystem was awarded the Certificate of Compliance with Standard EN ISO 9001:2000 by the Italian Quality Assurance Institute IGQ (No. 2B45) for its “design, manufacture and commercial distribution of drainage systems, manhole covers and gratings marked Mufle – Commercial distribution of products for the building industry”.

The Standards ISO 9000 set forth a series of regulations to be met in order to rationalise work, meet customers’ expectations, maintain and improve the quality system.

The Certificate makes it possible for the Company to cut mistakes and boost its organisation structure by carefully defining its corporate procedures, from resource management to product manufacture, including the definition of responsibilities and the analysis and improvement of its processes.

All processes are handled on a systematic and organic basis in order to increase customer satisfaction and ensure working consistency in the production of goods.

MufleSystem decision to obtain the Certification made it possible to achieve major results such as: systematic nature, method, system soundness, spurs to improvement, customer satisfaction, better internal and external relationships.



# MUFLEDRAIN

WATER CONVEYING SYSTEMS



Thanks to the **wide range** of channels and the different types of covering gratings, the MufleDrain system makes it possible to meet **all** drainage **requirements** in the civil and industrial sectors.

Today it is even **cheaper and more efficient** thanks to the new male-female coupling system, designed to let you lay the channels with utmost **SIMPLICITY** with **preassembled gratings!**



A51 tangenziale est  
 E 35 A1 BOLOGNA  
 E 62 A7 GENOVA

MILANO   
 Linate



**A4 MILANO EST - BERGAMO**



**STIAMO  
 REALIZZANDO  
 LA 4ª CORSIA  
 (34 Km)**

STATO DELL'OPERA	APERTURA AL TRAFFICO PREVISTA
MILANO EST - AGRATE (10 Km)	Lavori in corso <b>MAGGIO 2007</b>
AGRATE - TREZZO (9 Km)	Lavori in corso <b>OTTOBRE 2006</b>
TREZZO - BERGAMO (14 Km)	Lavori in corso <b>LUGLIO 2007</b>

**DIMENSIONI DELL'OPERA**

Importo dei lavori:	346 milioni di €
Importo interventi in favore del territorio:	44 milioni di €
Barriere antirumore:	29 Km

**autostrade** // per l'italia

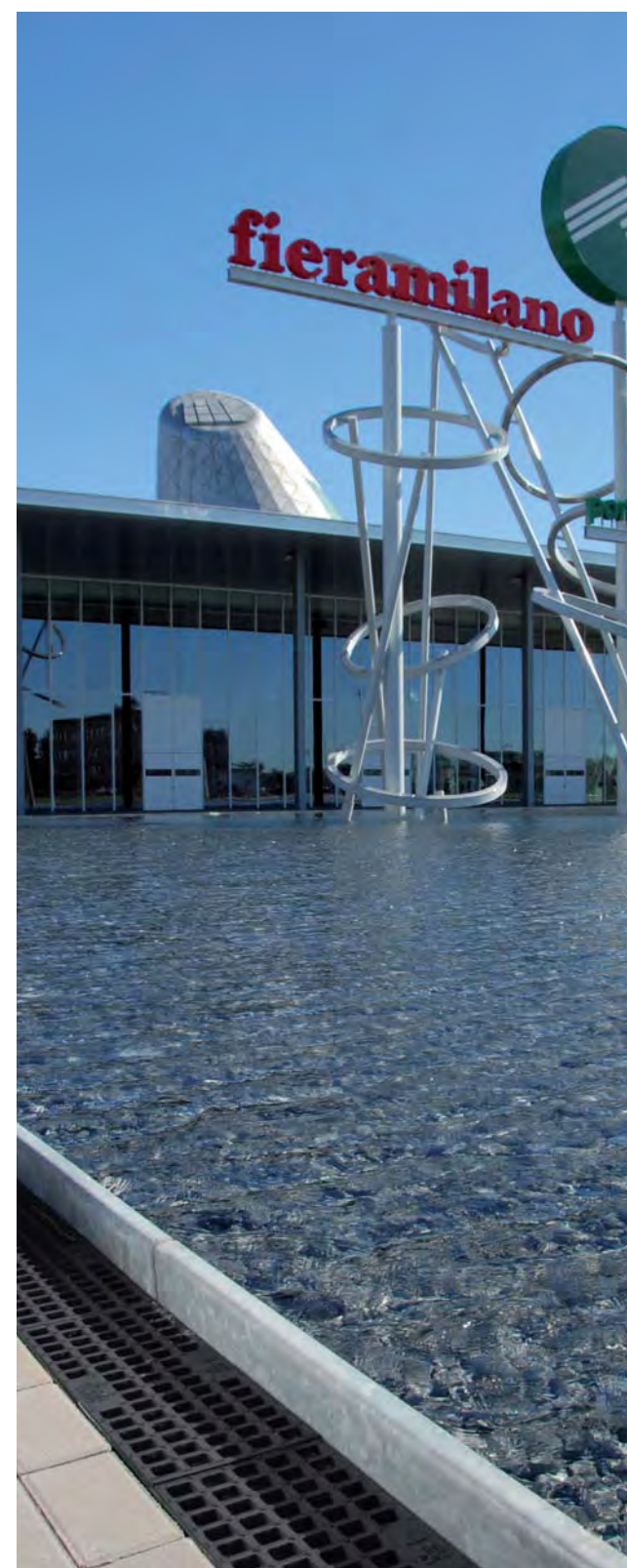

The words “Certified Product” should give rise to two questions: Which features were certified? Who certified them? These words do not show a general quality with the product but the presence of something more (well-defined and verifiable) than in the competing products.

The steps taken to certify a product aim to inform the customer of some major peculiar features that make our products stand out from products from the same category.

To certify a product means highlighting its explicit and implicit features and stating the Company’s commitment to a continuous search for standards able to ensure higher and higher quality requirements. Certified products result from continuous improvement based on well-defined quality standards and continuous monitoring by an independent Certifier.

In short we can say that product certification means that the Company has voluntarily chosen to enter into a trust-based agreement with its customers in order to assure them its products have specified **SAFETY** and quality features.

## THE CE MARK



Certain types of products bear the CE Mark to show that they meet or are compliant with all the applicable European Union Directives. In order to be marketed in the countries belonging to the European Economic Area (EEA) the laws require the products to bear the Mark. The symbol CE stands for “Conformité Européenne” and shows that the product complies with the essential requirements specified by Directives on safety, public health and protection of consumers.

Said requirements are summarised in the European Directive 89/106 EEC, transposed in Italy with a Decree by the President of the Italian Republic (No. 246/93) aimed to ensure the free movement of construction products and the lifting of all national protectionist barriers in EU countries.

## The CE Mark :

- shows that the product underwent conformity assessment procedures;
- ensures the product complies with all applicable EU requirements imposed on the manufacturer;
- can be affixed only when all audits have been completed;
- entitles the product to be marketed, to move freely and to be used on the EC territory;
- must be affixed by the manufacturer;
- is made up of the letters CE and, should a notified body take part in the production audit phase, of the identification number of said body or bodies;
- must be visible, readable, indelible, and must be affixed on the product directly.

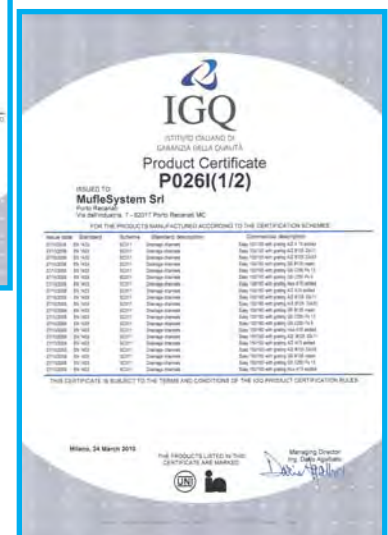







European Standard EN 1433 is aimed to define the “terminology, classification, test, design, marking and conformity assessment requirements of linear drainage channels to collect and carry surface water as installed in areas subject to pedestrian and/or vehicular traffic”.

MufleSystem’s HD-PE drainage channels and the relevant gratings and covers (made of galvanised/stainless steel or ductile cast iron) are certified according to Standard EN 1433 on “Drainage Channels for Pedestrian and Vehicular Areas”.

The certificate, issued by the Italian Quality Assurance Institute IGQ, is a guarantee for the final customer that the products are manufactured with high-quality manufacturing processes (either carried out in-house or outside) and comply with the reference specifications.

This also ensures that the regular checks specified by Standard EN 1433 are carried out, since MufleSystem continuously performs load tests on its products in its own in-house laboratory, as well as physical and chemical analyses on polyethylene, metallographic analyses and tensile tests on cast iron in external certified laboratories.

	<b>Class A1</b>	Areas which can only be used by pedestrians and pedal cyclists, green areas.
	<b>Class B125</b>	Footways, pedestrian areas and comparable areas, private car parks and parking decks.
	<b>Class C250</b>	Roadside areas (kerbs) stretching maximum 0.5 m into the carriageway and maximum 0.2 m into the footway.
	<b>Class D400</b>	Carriageways of roads (pedestrian streets included), hard shoulders and parking areas for all types of road vehicles.
	<b>Class E600</b>	Areas subject to high loads such ports, industrial areas and areas where goods are unloaded.
	<b>Class F900</b>	Areas subject to very high loads such as airports and areas where containers are unloaded.

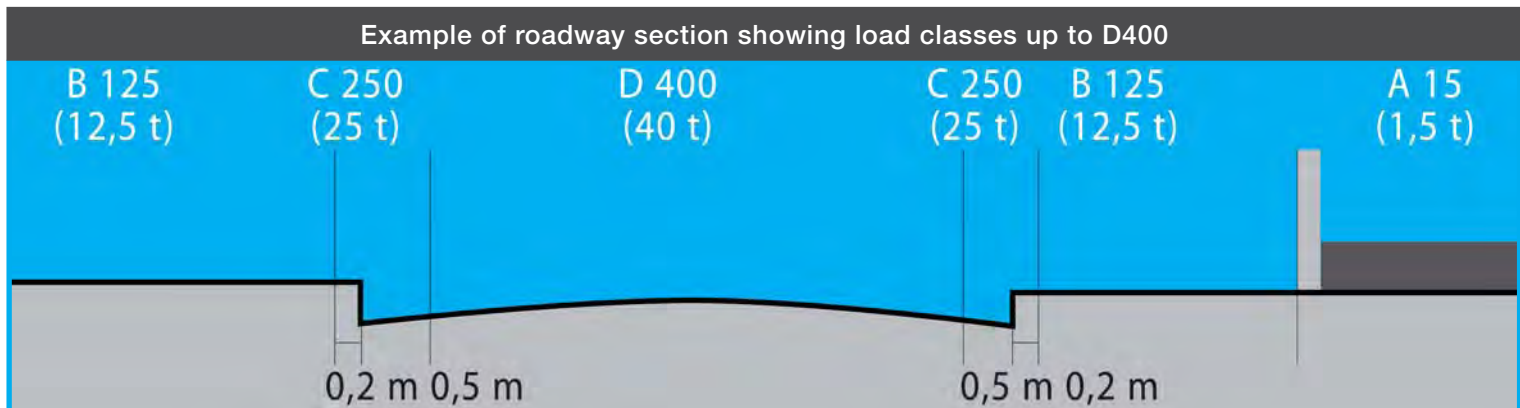

# FLat

## The system:

- it supports 3 load classes (A15, B125, C250) in compliance with Standard EN 1433
- it is made up of a channel - entirely made from HD-PE - which needs no strengthening frame
- it has a wide usable section for drainage and uses lightweight gratings with optimised sizes
- it has a small size thanks to its flat bottom to which a convenient drain gate can be screwed, if needed
- it comprises 4 different types of gratings (with rungs, slots, square mesh, anti-heel mesh) made from galvanised steel, stainless steel and ductile cast-iron
- it is supplemented with different fixing systems, which are ideal for all requirements and range from the classic tie-rod to a simple locking system using a protrusion inside the channel
- it is ideal whenever there is little installation space such as in underground car parks or parking decks, flat roofs, terraces
- it is ideal whenever high-quality aesthetic finishes are to be achieved, since the gratings rest directly on the channel's contact surface, thus covering it completely
- it comes complete with drain gullies with siphon
- the range is made up of 2 channels with 1 width and 2 heights (100/55 and 100/80)

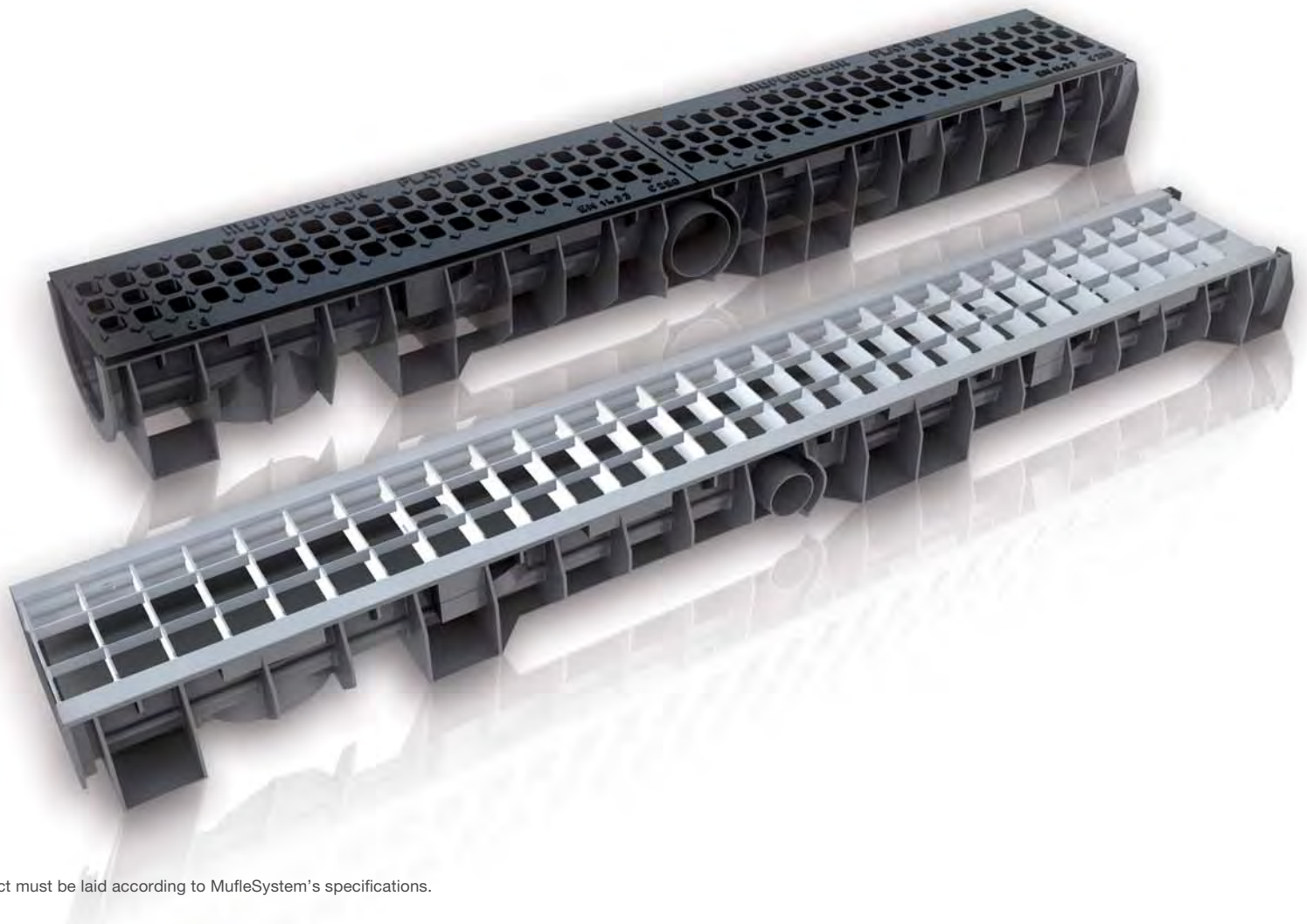

The product must be laid according to MufleSystem's specifications.



# INSTALLATION

## “For all the drainage channels the manufacturer shall supply written instructions for general installation” (Ref. § 7.17 EN 1433)

The installation instructions enclosed in the present technical section are given only as an example in order to supply the main guide lines to the final fitter.

Any particular installation must be evaluated/ agreed between MufleSystem srl and the project maker.

The correct installation is necessary to guarantee the proper loads resistance of the drainage system (channel and grating) to static and dynamical traffic which is subjected to.

The correct installation involves a longer operational length of the drainage system itself as well as its better hydraulic function.

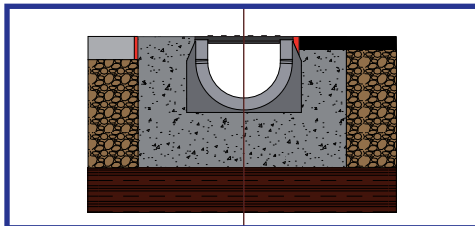
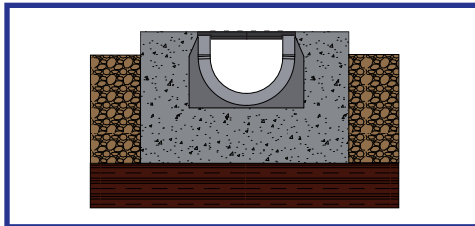
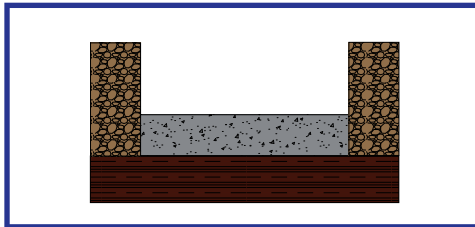
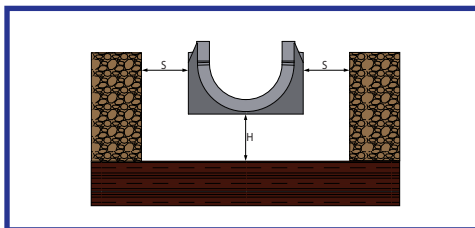

**NEW FEATURE:**  
The channels can be installed with preassembled gratings.

### Step 1

#### HOLE SIZE

The hole needed to lay the MufleDrain channel must allow not only for the size of the channel and the drain piping but also for adequate space for the base H and the side concrete props S. The dimensions to be followed are shown in the Summary Table. In this step make sure the underlying layer is suitable to the load it is expected to support.

### Step 2

#### CONCRETE BASE

Cast the concrete base H up to the height specified, allowing for any inclination in the drainage line. In case that cycles of loading and unloading are often (for example: periodic transit of vehicles) or the loads are particular heavy (E600 - F900), we recommended to reinforce the concrete base with an electro-welded net or with or beaded mouldings Ø 8 with mesh 15x15 cm. At this stage it is needed to arrange possible slopes of the drainage line.

### Step 3

#### CHANNEL ARRANGEMENT

Lay the channels starting from the flow outlet and block them at basis in order to avoid any floating or misalignment during the concrete casting for the side prop.

Allow for the drains required and build the side prop S up to the maximum height allowed by the final coating. Shape it according to the needs based on the drawing. Introduce and fix the grating required beforehand in order to prevent any deformation of the channel due to the thrust of concrete and to speed up installation.

As well as the step 2, also for the side prop concrete arrange the reinforcement.

### Step 4

#### FINAL COATING

When applying the final coating, make sure its upper profile reaches up to minimum 3/5 mm above the grating's flow plane.

## Recommendations for installation

- In case that channels watertightness is requested, MufleSystem is purposely recommending the use of a bituminous silicone sealant “SHELL TIXOPHALTE”: after carrying out the side prop, apply a thin and homogeneous sealant strip on each slot between the channels and the following one (clean the eventual exceeding sealant). It is strongly advised not to apply the strips of “SHELL TIXOPHALTE” inside the slots in the female joint of the channels before coupling them. Eventually a through and long- lasting guarantees to avoid any leakages can be obtained by welding the joints; this requires welding machines and experienced technicians.
- While carrying out the phase 2 and 3, protect the gratings with a PVC film so that no final cleaning must be carried out to remove any concrete residues.
- In case the drainage line is subjected to horizontal loads (for example concrete casting for industrial paving, private car parks and parking decks), it is necessary to arrange effective expansion joints for both direction, parallel and perpendicular to the channels. These joints shall be placed according to the norm standards in force and shall not be placed close to drainage line.
- In case the drainage line shall be installed on roofs or terraces, it is obligatory to arrange a waterproof sheet according to specific projects.



N.B. MufleSystem srl reserves the right to change the technical characteristics herein specified without prior notice. Said technical characteristics are given for information purposes only and are subject to changes as our products are developed.



# INSTALLATION

flat

## Case 1 Flooring (A15-B125-C250)

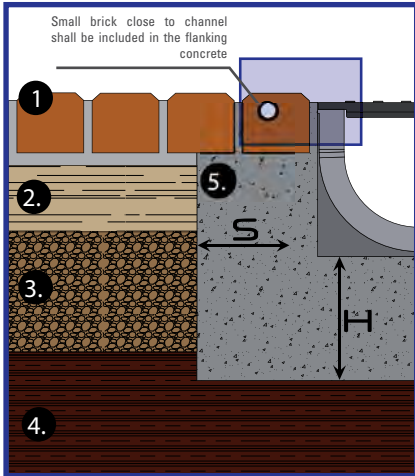

1. Flooring
2. Lower bed layer
3. Bearing layer
4. Subfloor
5. Concrete reinforcement layer

## Case 2 Concrete flooring (A15-B125-C250)

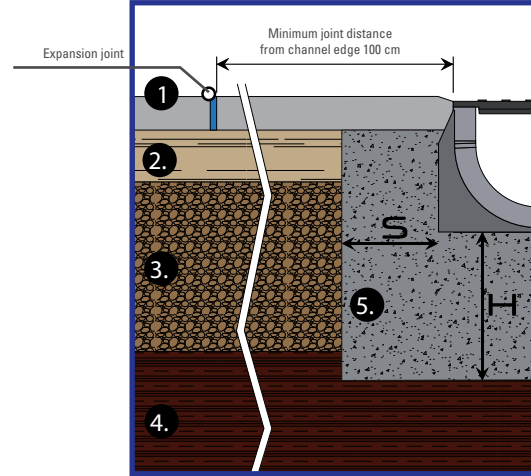

1. Flooring
2. Lower bed layer
3. Bearing layer
4. Subfloor
5. Concrete reinforcement layer
6. Expansion joint

## Case 3 Asphalt (A15-B125-C250)

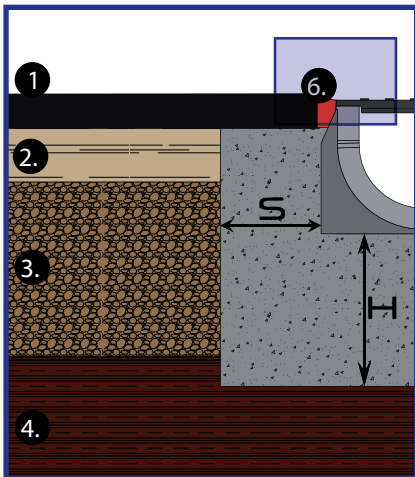

1. Flooring
2. Lower bed layer
3. Bearing layer
4. Subfloor
5. Concrete reinforcement layer
6. Safety joint (if required)

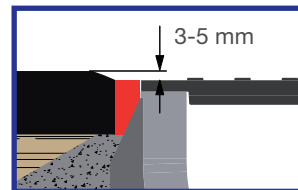

This Sheet is only aimed to give advice on the installation of channels mod. MufleDrain. In any case, always:

- check the carrying capacity characteristics of the underlying layer
- we recommend using Class S4 concrete (EN 206-1) and stone aggregate with maximum diameter 8 mm.
- comply with the height of the installation surface and the thickness of the prop as specified according to the load classes.

### SUMMARY TABLE

Load class (EN 1433)		A 15	B 125	C 250
Applicable load (EN 1433)	kN	15	125	250
Minimum height H of concrete laying bed	mm	100	100	150
Minimum thickness S of the concrete fl anking	mm	100	100	150
Concrete compression strength class (EN 206-1)		C 20/25	C 25/30	C 25/30
Concrete compression strength class' (EN 206-1)		C 30/37 XF4	C 30/37 XF4	C 30/37 XF4

7- If concrete can be affected by frost and thaw cycles.

N.B. MufleSystem srl reserves the right to change the technical characteristics herein specified without prior notice. Said technical characteristics are given for information purposes only and are subject to changes as our products are developed.

N.B. Sizes and weights are subject to usual manufacturing tolerance values.



# easy

The system:

- it supports 3 load classes (A15, B125, C250) in compliance with Standard EN 1433
- it is made up of a channel - entirely made from HD-PE - which needs no strengthening frame
- it comprises 4 different types of gratings (with rungs, slots, square mesh, anti-heel mesh) made from galvanised steel, stainless steel and ductile cast-iron
- it is supplemented with a whole series of L-shaped longitudinal- slot gratings in class C250 equipped also with drain boxes
- it comes equipped with a classic tie-rod fixing system
- it is ideal for household and civil uses, pedestrian areas, private car parks, footways, canalisation systems in roads and parking areas
- is ideal whenever high-quality aesthetic finishes are to be achieved, since the gratings rest directly on the channel's contact surface, thus covering it completely
- it comes complete with drain gullies with siphon
- the range is made up of 10 channels with 3 widths and 5 heights (100/55, 100/80, 100/100, 100/160, 150/40, 150/100, 150/160, 200/40, 200/100, 200/160, 200/250)



The product must be laid according to MufleSystem's specifications.



# INSTALLATION

**easy**

## “For all the drainage channels the manufacturer shall supply written instructions for general installation” (Ref. § 7.17 EN 1433)

The installation instructions enclosed in the present technical section are given only as an example in order to supply the main guide lines to the final fitter.

Any particular installation must be evaluated/ agreed between MufleSystem srl and the project maker.

The correct installation is necessary to guarantee the proper loads resistance of the drainage system (channel and grating) to static and dynamical traffic which is subjected to.

The correct installation involves a longer operational length of the drainage system itself as well as its better hydraulic function.

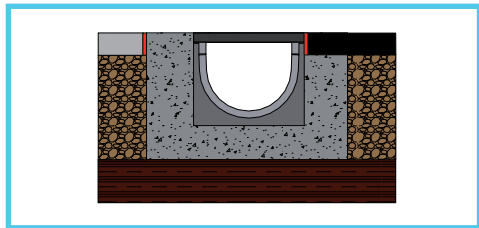
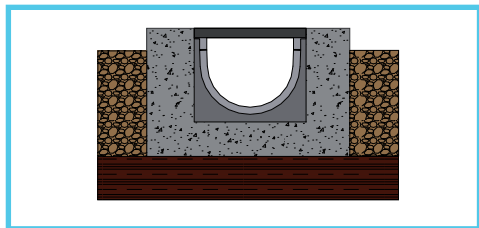
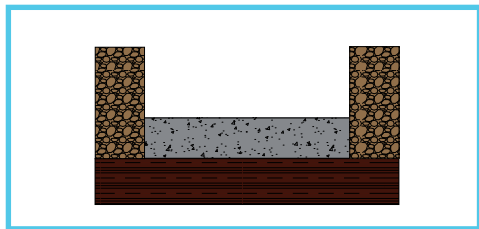
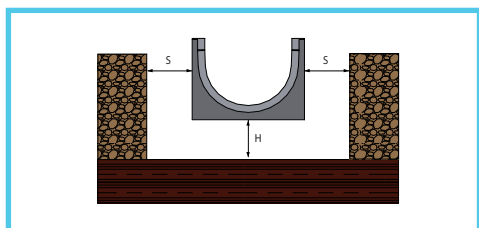

**NEW FEATURE:**  
The channels can be installed with preassembled gratings.

### Step 1

#### HOLE SIZE

The hole needed to lay the MufleDrain channel must allow not only for the size of the channel and the drain piping but also for adequate space for the base H and the side concrete props S. The dimensions to be followed are shown in the Summary Table. In this step make sure the underlying layer is suitable to the load it is expected to support.

### Step 2

#### CONCRETE BASE

Cast the concrete base H up to the height specified, allowing for any inclination in the drainage line. In case that cycles of loading and unloading are often (for example: periodic transit of vehicles) or the loads are particular heavy (E600 - F900), we recommended to reinforce the concrete base with a electro-welded net or with or beaded mouldings Ø 8 with mesh 15x15 cm. At this stage it is needed to arrange possible slopes of the drainage line.

### Step 3

#### CHANNEL ARRANGEMENT

Lay the channels starting from the flow outlet and block them at basis in order to avoid any floating or misalignment during the concrete casting for the side prop.

Allow for the drains required and build the side prop S up to the maximum height allowed by the final coating. Shape it according to the needs based on the drawing. Introduce and fix the grating required beforehand in order to prevent any deformation of the channel due to the thrust of concrete and to speed up installation.

As well as the step 2, also for the side prop concrete arrange the reinforcement.

### Step 4

#### FINAL COATING

When applying the final coating, make sure its upper profile reaches up to minimum 3/5 mm above the grating's flow plane.

## Recommendations for installation

1. In case that channels watertightness is requested, MufleSystem is purposely recommending the use of a bituminous silicone sealant “SHELL TIXOPHALTE”: after carrying out the side prop, apply a thin and homogeneous sealant strip on each slot between the channels and the following one (clean the eventual exceeding sealant). It is strongly advised not to apply the strips of “SHELL TIXOPHALTE” inside the slots in the female joint of the channels before coupling them. Eventually a through and long- lasting guarantees to avoid any leakages can be obtained by welding the joints; this requires welding machines and experienced technicians.
2. While carrying out the phase 2 and 3, protect the gratings with a PVC film so that no final cleaning must be carried out to remove any concrete residues.
3. In case the drainage line is subjected to horizontal loads (for example concrete casting for industrial paving, private car parks and parking decks), it is necessary to arrange effective expansion joints for both direction, parallel and perpendicular to the channels. These joints shall be placed according to the norm standards in force and shall not be placed close to drainage line.
4. In case the drainage line shall be installed on roofs or terraces, it is obligatory to arrange a waterproof sheet according to specific projects.



N.B. MufleSystem srl reserves the right to change the technical characteristics herein specified without prior notice. Said technical characteristics are given for information purposes only and are subject to changes as our products are developed.



# INSTALLATION

**easy**

## Case 1 Flooring (A15-B125-C250)

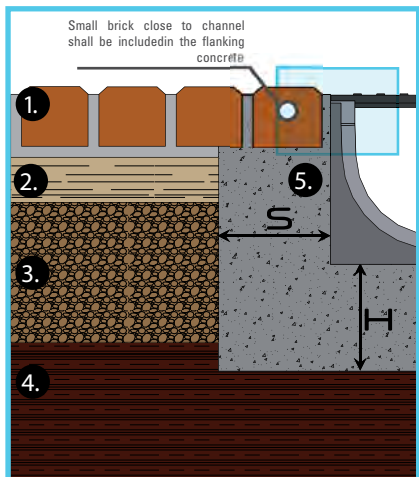

1. Flooring
2. Lower bed layer
3. Bearing layer
4. Subfloor
5. Concrete reinforcement layer

## Case 2 Concrete flooring (A15-B125-C250)

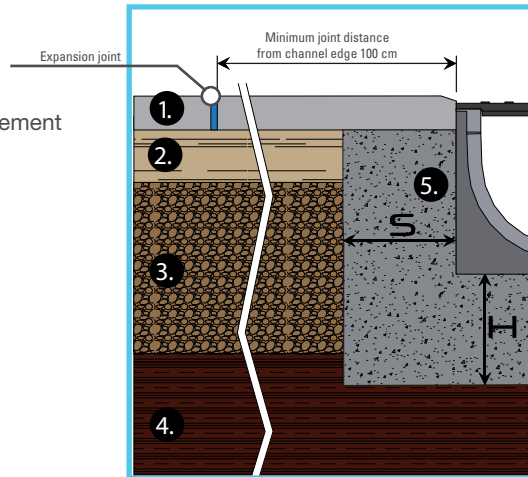

1. Flooring
2. Lower bed layer
3. Bearing layer
4. Subfloor
5. Concrete reinforcement layer
6. Expansion joint

## Case 3 Asphalt (A15-B125-C250)

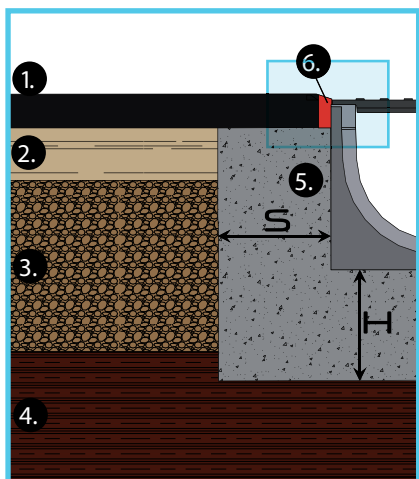

1. Flooring
2. Lower bed layer
3. Bearing layer
4. Subfloor
5. Concrete reinforcement layer
6. Safety joint (if required)

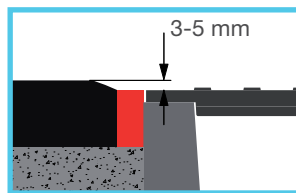

This Sheet is only aimed to give advice on the installation of channels mod. MufleDrain. In any case, always:

- check the carrying capacity characteristics of the underlying layer
- we recommend using Class S4 concrete (EN 206-1) and stone aggregate with maximum diameter 8 mm.
- comply with the height of the installation surface and the thickness of the prop as specified according to the load classes

### SUMMARY TABLE

Load class (EN 1433)		A 15	B 125	C 250
Applicable load (EN 1433)	kN	15	125	250
Minimum height H of concrete laying bed	mm	100	100	150
Minimum thickness S of the concrete flanking	mm	100	100	150
Concrete compression strength class (EN 206-1)		C 20/25	C 25/30	C 25/30
Concrete compression strength class (EN 206-1)		C 30/37 XF4	C 30/37 XF4	C 30/37 XF4

7- If concrete can be affected by frost and thaw cycles.

N.B. MufleSystem srl reserves the right to change the technical characteristics herein specified without prior notice. Said technical characteristics are given for information purposes only and are subject to changes as our products are developed.

N.B. Sizes and weights are subject to usual manufacturing tolerance values.



# INSTALLATION SLOTTED GRATING LONGITUDINALE

**easy**

**Case 1**  
Flooring  
(A15-B125-C250)

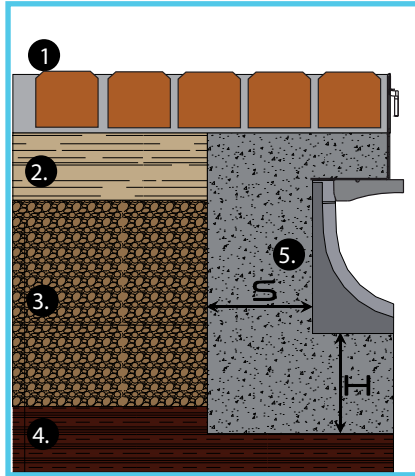

1. Flooring
2. Lower bed layer
3. Bearing layer
4. Subfloor
5. Concrete reinforcement layer

**Case 2**  
Concrete flooring  
(A15-B125-C250)

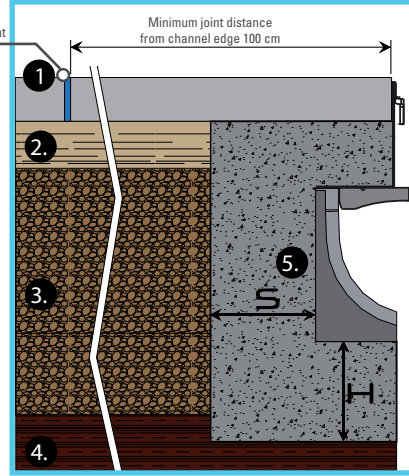

1. Flooring
2. Lower bed layer
3. Bearing layer
4. Subfloor
5. Concrete reinforcement layer
6. Expansion joint

**Case 3**  
Asphalt  
(A15-B125-C250)

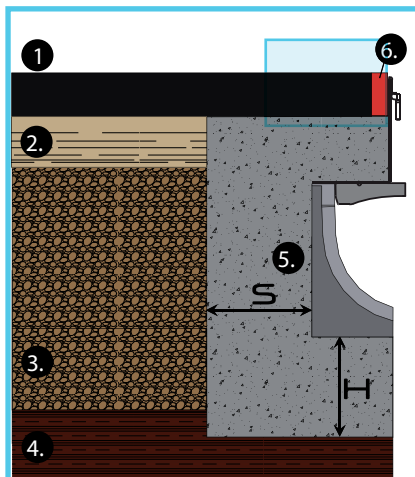

1. Flooring
2. Lower bed layer
3. Bearing layer
4. Subfloor
5. Concrete reinforcement layer
6. Safety joint (if required)

This Sheet is only aimed to give advice on the installation of channels mod. MufleDrain. In any case, always:

- check the carrying capacity characteristics of the underlying layer
- we recommend using Class S4 concrete (EN 206-1) and stone aggregate with maximum diameter 8 mm.
- comply with the height of the installation surface and the thickness of the prop as specified according to the load classes.

## SUMMARY TABLE

Load class (EN 1433)		A 15	B 125	C 250
Applicable load (EN 1433)	kN	15	125	250
Minimum height H of concrete laying bed	mm	100	100	150
Minimum thickness S of the concrete fl anking	mm	100	100	150
Concrete compression strength class (EN 206-1)		C 20/25	C 25/30	C 25/30
Concrete compression strength class (EN 206-1)		C 30/37 XF4	C 30/37 XF4	C 30/37 XF4

7- If concrete can be affected by frost and thaw cycles.

N.B. MufleSystem srl reserves the right to change the technical characteristics herein specified without prior notice. Said technical characteristics are given for information purposes only and are subject to changes as our products are developed.

N.B. Sizes and weights are subject to usual manufacturing tolerance values.

# SKIP

## The system:

- it supports 3 load classes (A15, B125, C250) in compliance with Standard EN 1433
- it is made up of a channel - entirely made from HD-PE - which has a 20 mm high toe board and needs no strengthening frame
- it has a wide usable section for drainage and uses lightweight gratings with optimised sizes
- it comprises a wide range of different gratings (with rungs, slots, square mesh, anti-heel mesh) made from galvanised steel, stainless steel, ductile cast-iron and HD-PE. A HD-PE blind cover is available too.
- it is supplemented with different fixing systems, which are ideal for all requirements and range from the classic tie-rod to a simple locking system using a protrusion inside the channel
- grating protection is ensured by the HD-PE edge
- it comes equipped with a convenient drain gate, which minimises its size
- since the edge shows the exact dimensions for the paving, easy and accurate installation is ensured
- it is ideal for residential areas, sport facilities, private car parks.
- it comes complete with drain gullies with siphon
- the range is made up of 2 channels with 1 width and 2 heights (100/55 and 100/80)

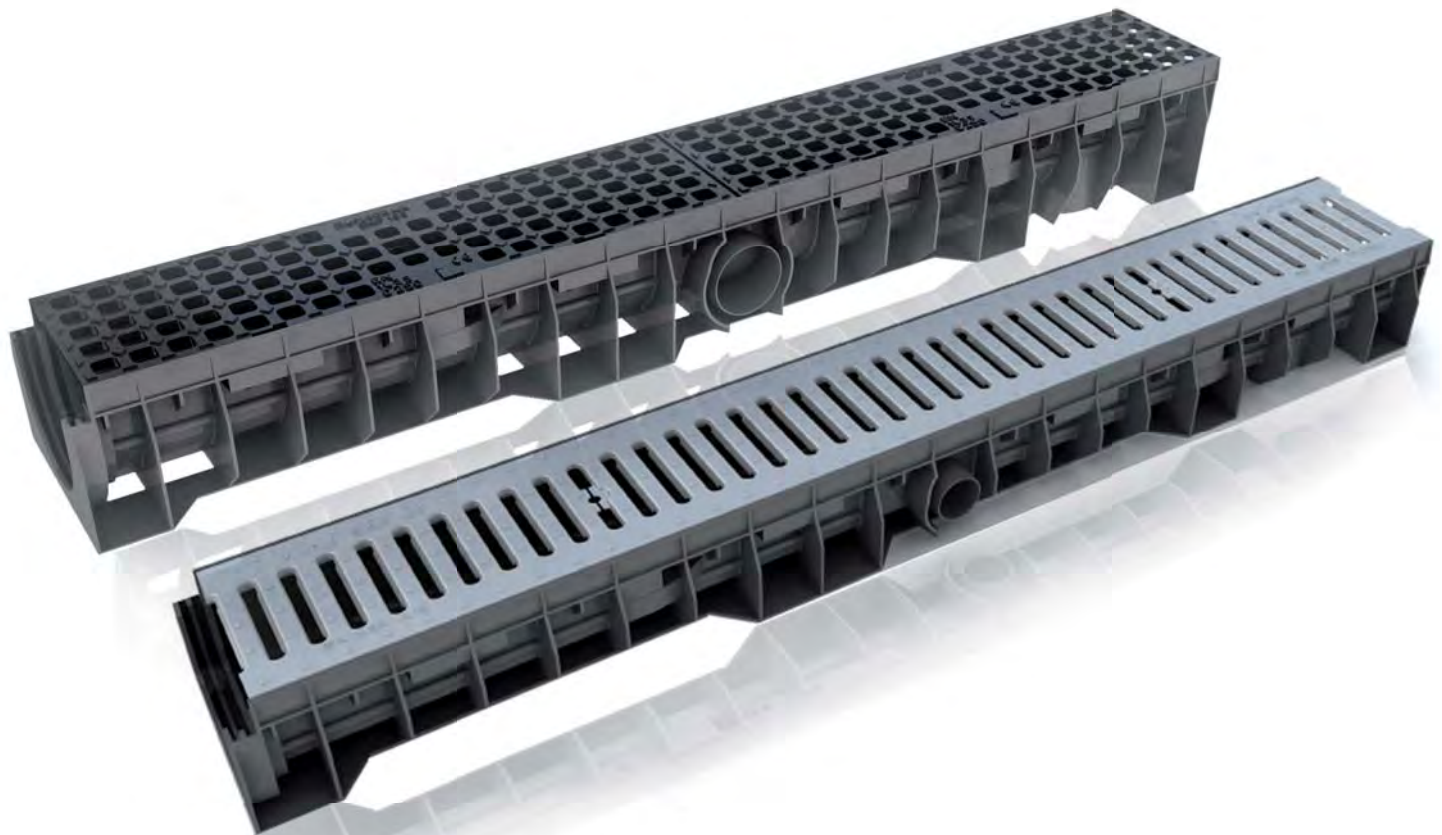

The product must be laid according to MufleSystem's specifications.



# INSTALLATION

skip

## “For all the drainage channels the manufacturer shall supply written instructions for general installation” (Ref. § 7.17 EN 1433)

The installation instructions enclosed in the present technical section are given only as an example in order to supply the main guide lines to the final fitter.

Any particular installation must be evaluated/ agreed between MufleSystem srl and the project maker.

The correct installation is necessary to guarantee the proper loads resistance of the drainage system (channel and grating) to static and dynamical traffic which is subjected to.

The correct installation involves a longer operational length of the drainage system itself as well as its better hydraulic function.

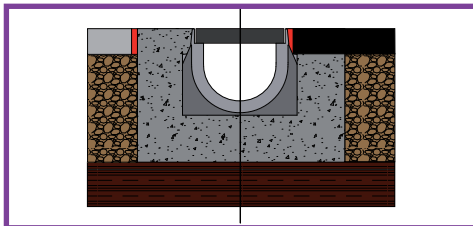
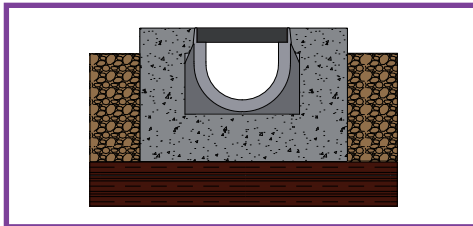
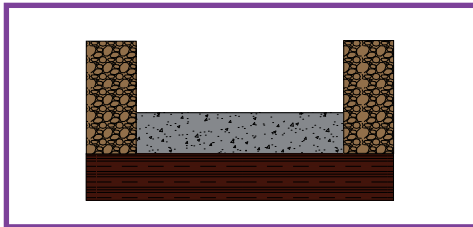
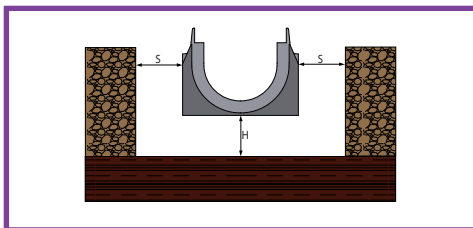

**NEW FEATURE:**  
The channels can be installed with preassembled gratings

### Step 1

#### HOLE SIZE

The hole needed to lay the MufleDrain channel must allow not only for the size of the channel and the drain piping but also for adequate space for the base H and the side concrete props S. The dimensions to be followed are shown in the Summary Table. In this step make sure the underlying layer is suitable to the load it is expected to support.

### Step 2

#### CONCRETE BASE

Cast the concrete base H up to the height specified, allowing for any inclination in the drainage line. In case that cycles of loading and unloading are often (for example: periodic transit of vehicles) or the loads are particular heavy (E600 - F900), we recommended to reinforce the concrete base with a electro-welded net or with or beaded mouldings Ø 8 with mesh 15x15 cm. At this stage it is needed to arrange possible slopes of the drainage line.

### Step 3

#### CHANNEL ARRANGEMENT

Lay the channels starting from the flow outlet and block them at basis in order to avoid any floating or misalignment during the concrete casting for the side prop.

Allow for the drains required and build the side prop S up to the maximum height allowed by the final coating. Shape it according to the needs based on the drawing. Introduce and fix the grating required beforehand in order to prevent any deformation of the channel due to the thrust of concrete and to speed up installation.

As well as the step 2, also for the side prop concrete arrange the reinforcement.

### Step 4

#### FINAL COATING

When applying the final coating, make sure its upper profile reaches up to minimum 3/5 mm above the grating's flow plane.

## Recommendations for installation

1. In case that channels watertightness is requested, MufleSystem is purposely recommending the use of a bituminous silicone sealant “SHELL TIXOPHALTE”: after carrying out the side prop, apply a thin and homogeneous sealant strip on each slot between the channels and the following one (clean the eventual exceeding sealant). It is strongly advised not to apply the strips of “SHELL TIXOPHALTE” inside the slots in the female joint of the channels before coupling them. Eventually a through and long- lasting guarantees to avoid any leakages can be obtained by welding the joints; this requires welding machines and experienced technicians.
2. While carrying out the phase 2 and 3, protect the gratings with a PVC film so that no final cleaning must be carried out to remove any concrete residues.
3. In case the drainage line is subjected to horizontal loads (for example concrete casting for industrial paving, private car parks and parking decks), it is necessary to arrange effective expansion joints for both direction, parallel and perpendicular to the channels. These joints shall be placed according to the norm standards in force and shall not be placed close to drainage line.
4. In case the drainage line shall be installed on roofs or terraces, it is obligatory to arrange a waterproof sheet according to specific projects.



N.B. MufleSystem srl reserves the right to change the technical characteristics herein specified without prior notice. Said technical characteristics are given for information purposes only and are subject to changes as our products are developed.



# INSTALLATION

skip

## Case 1 Flooring (A15-B125-C250)

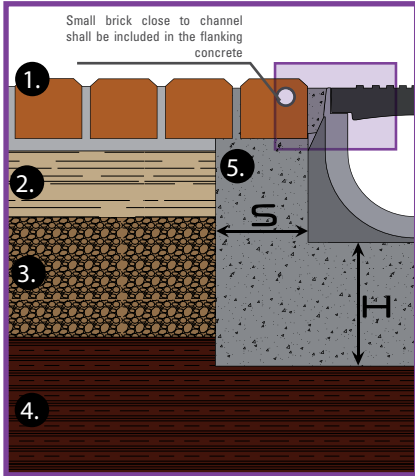

1. Flooring
2. Lower bed layer
3. Bearing layer
4. Subfloor
5. Concrete reinforcement layer

## Case 2 Concrete flooring (A15-B125-C250)

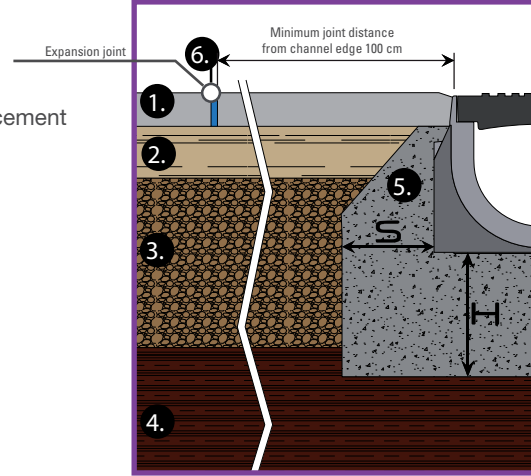

1. Flooring
2. Lower bed layer
3. Bearing layer
4. Subfloor
5. Concrete reinforcement layer
6. Expansion joint

## Case 3 Asphalt (A15-B125-C250)

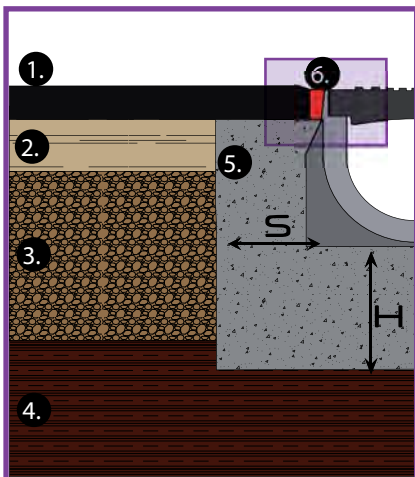

1. Flooring
2. Lower bed layer
3. Bearing layer
4. Subfloor
5. Concrete reinforcement layer
6. Bitumen joint

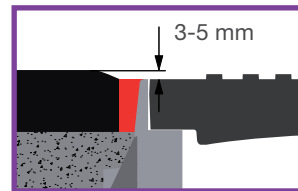

This Sheet is only aimed to give advice on the installation of channels mod. MufleDrain. In any case, always:

- check the carrying capacity characteristics of the underlying layer
- we recommend using Class S4 concrete (EN 206-1) and stone aggregate with maximum diameter 8 mm.
- comply with the height of the installation surface and the thickness of the prop as specified according to the load classes.

### SUMMARY TABLE

Load class (EN 1433)		A 15	B 125	C 250
Applicable load (EN 1433)	kN	15	125	250
Minimum height H of concrete laying bed	mm	100	100	150
Minimum thickness S of the concrete flanking	mm	100	100	150
Concrete compression strength class (EN 206-1)		C 20/25	C 25/30	C 25/30
Concrete compression strength class <sup>7</sup> (EN 206-1)		C 30/37 XF4	C 30/37 XF4	C 30/37 XF4

7- If concrete can be affected by frost and thaw cycles.

N.B. MufleSystem srl reserves the right to change the technical characteristics herein specified without prior notice. Said technical characteristics are given for information purposes only and are subject to changes as our products are developed.

N.B. Sizes and weights are subject to usual manufacturing tolerance values.



The system:

- it supports 3 load classes (A15, B125, C250) in compliance with Standard EN 1433
- it is made up of a channel - entirely made from HD-PE - which has a 20 mm - high toeboard and needs no strengthening frame
- grating protection is ensured by the HD-PE edge
- since the edge shows the exact dimensions for the paving, easy and accurate installation is ensured
- it comprises a wide range of different gratings (with rungs, slots, square mesh, anti-heel mesh) made from galvanised steel, stainless steel, ductile cast-iron and HD-PE. A HD-PE blind cover is available too
- it is supplemented with a whole series of L-shaped longitudinal- slot gratings in class C250 equipped also with drain boxes
- it comes equipped with a classic tie-rod fixing system and a convenient side coupling system through a tab inside the HD-PE gratings
- it is ideal for civil uses, pedestrian areas, private car parks, footways, canalisation systems in parking areas, sport facilities, synthetic tracks, athletics grounds
- it comes complete with drain gullies with siphon
- the range is made up of 11 channels with 3 widths and 6 heights (100/55, 100/80, 100/100, 100/160, 150/40, 150/100, 150/160, 200/40, 200/100, 200/160, 200/250)
- the range is supplemented with the VIP channel with length 1.5 m and usable dimensions 300 x 300 mm. Designed to drain large surfaces

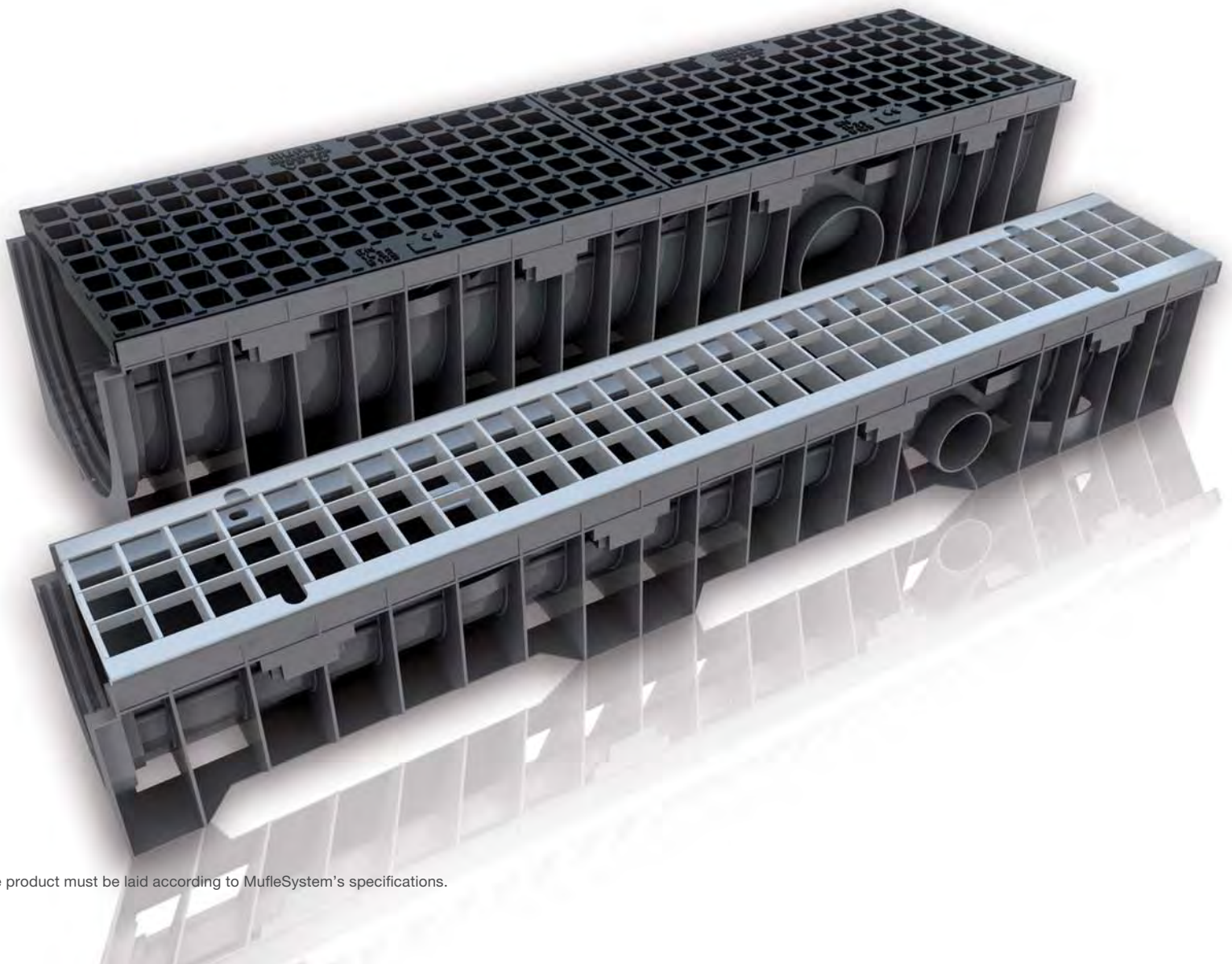





# INSTALLATION



## “For all the drainage channels the manufacturer shall supply written instructions for general installation” (Ref. § 7.17 EN 1433)

The installation instructions enclosed in the present technical section are given only as an example in order to supply the main guide lines to the final fitter.

Any particular installation must be evaluated/ agreed between MufleSystem srl and the project maker.

The correct installation is necessary to guarantee the proper loads resistance of the drainage system (channel and grating) to static and dynamical traffic which is subjected to.

The correct installation involves a longer operational length of the drainage system itself as well as its better hydraulic function.

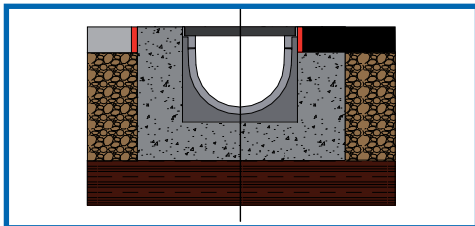
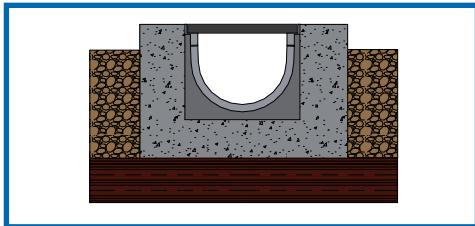
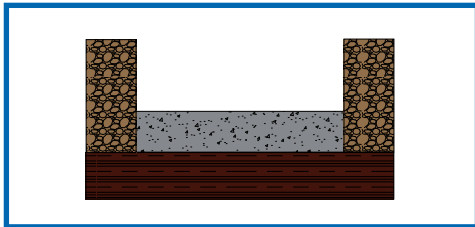
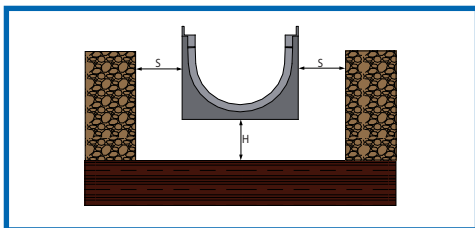

**NEW FEATURE:**  
The channels can be installed with preassembled gratings.

### Step 1 HOLE SIZE

The hole needed to lay the MufleDrain channel must allow not only for the size of the channel and the drain piping but also for adequate space for the base H and the side concrete props S. The dimensions to be followed are shown in the Summary Table. In this step make sure the underlying layer is suitable to the load it is expected to support.

### Step 2 CONCRETE BASE

Cast the concrete base H up to the height specified, allowing for any inclination in the drainage line. In case that cycles of loading and unloading are often (for example: periodic transit of vehicles) or the loads are particular heavy (E600 - F900), we recommended to reinforce the concrete base with a electro-welded net or with or beaded mouldings Ø 8 with mesh 15x15 cm. At this stage it is needed to arrange possible slopes of the drainage line.

### Step 3 CHANNEL ARRANGEMENT

Lay the channels starting from the flow outlet and block them at basis in order to avoid any floating or misalignment during the concrete casting for the side prop.

Allow for the drains required and build the side prop S up to the maximum height allowed by the final coating. Shape it according to the needs based on the drawing. Introduce and fix the grating required beforehand in order to prevent any deformation of the channel due to the thrust of concrete and to speed up installation.

As well as the step 2, also for the side prop concrete arrange the reinforcement.

### Step 4 FINAL COATING

When applying the final coating, make sure its upper profile reaches up to minimum 3/5 mm above the grating's flow plane.

## Recommendations for installation

1. In case that channels watertightness is requested, MufleSystem is purposely recommending the use of a bituminous silicone sealant “SHELL TIXOPHALTE”: after carrying out the side prop, apply a thin and homogeneous sealant strip on each slot between the channels and the following one (clean the eventual exceeding sealant). It is strongly advised not to apply the strips of “SHELL TIXOPHALTE” inside the slots in the female joint of the channels before coupling them. Eventually a through and long- lasting guarantees to avoid any leakages can be obtained by welding the joints; this requires welding machines and experienced technicians.
2. While carrying out the phase 2 and 3, protect the gratings with a PVC film so that no final cleaning must be carried out to remove any concrete residues.
3. In case the drainage line is subjected to horizontal loads (for example concrete casting for industrial paving, private car parks and parking decks), it is necessary to arrange effective expansion joints for both direction, parallel and perpendicular to the channels. These joints shall be placed according to the norm standards in force and shall not be placed close to drainage line.
4. In case the drainage line shall be installed on roofs or terraces, it is obligatory to arrange a waterproof sheet according to specific projects.



N.B. MufleSystem srl reserves the right to change the technical characteristics herein specified without prior notice. Said technical characteristics are given for information purposes only and are subject to changes as our products are developed.



# INSTALLATION



## Case 1 Flooring (A15-B125-C250)

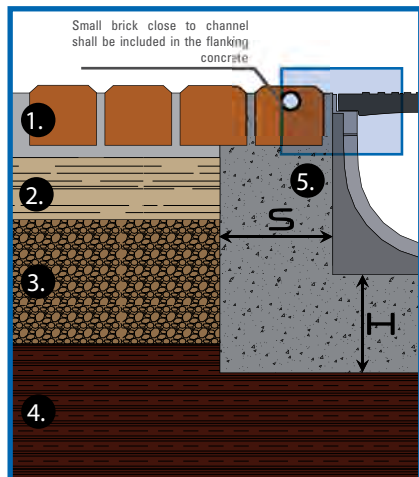

1. Flooring
2. Lower bed layer
3. Bearing layer
4. Subfloor
5. Concrete reinforcement layer

## Case 2 Concrete flooring (A15-B125-C250)

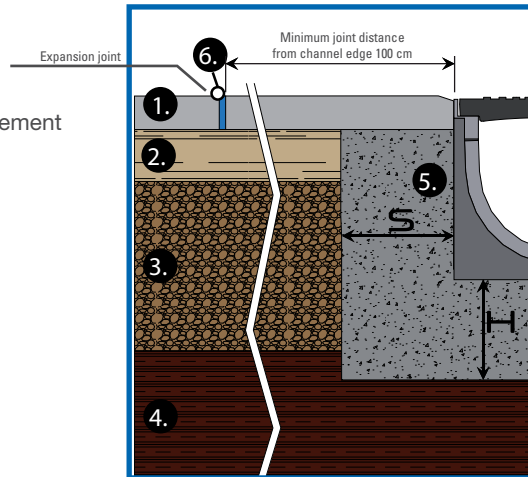

1. Flooring
2. Lower bed layer
3. Bearing layer
4. Subfloor
5. Concrete reinforcement layer
6. Expansion joint

## Case 3 Asphalt (A15-B125-C250)

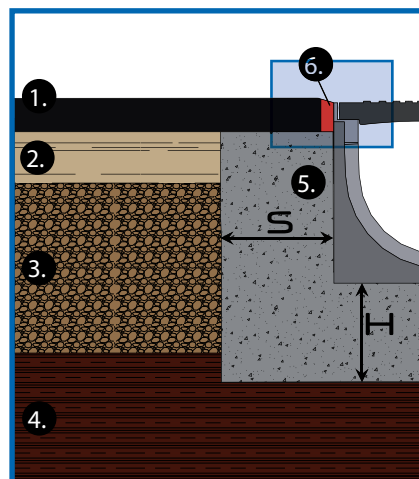

1. Flooring
2. Lower bed layer
3. Bearing layer
4. Subfloor
5. Concrete reinforcement layer
6. Safety joint (if required)

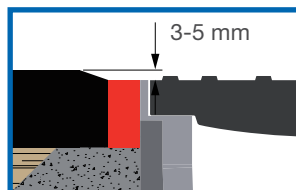

This Sheet is only aimed to give advice on the installation of channels mod. MufleDrain. In any case, always:

- check the carrying capacity characteristics of the underlying layer
- we recommend using Class S4 concrete (EN 206-1) and stone aggregate with maximum diameter 8 mm.
- comply with the height of the installation surface and the thickness of the prop as specified according to the load classes.

### SUMMARY TABLE

Load class (EN 1433)		A 15	B 125	C 250
Applicable load (EN 1433)	kN	15	125	250
Minimum height H of concrete laying bed	mm	100	100	150
Minimum thickness S of the concrete flanking	mm	100	100	150
Concrete compression strength class (EN 206-1)		C 20/25	C 25/30	C 25/30
Concrete compression strength class <sup>7</sup> (EN 206-1)		C 30/37 XF4	C 30/37 XF4	C 30/37 XF4

7- If concrete can be affected by frost and thaw cycles.

N.B. MufleSystem srl reserves the right to change the technical characteristics herein specified without prior notice. Said technical characteristics are given for information purposes only and are subject to changes as our products are developed.

N.B. Sizes and weights are subject to usual manufacturing tolerance values.



# INSTALLATION SLOTTED GRATING LONGITUDINALE



## Case 1 Flooring (A15-B125-C250)

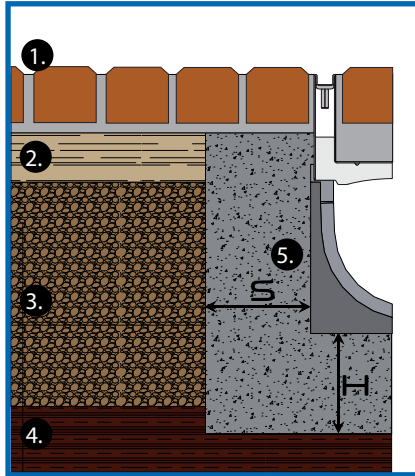

1. Flooring
2. Lower bed layer
3. Bearing layer
4. Subfloor
5. Concrete reinforcement layer

## Case 2 Concrete flooring (A15-B125-C250)

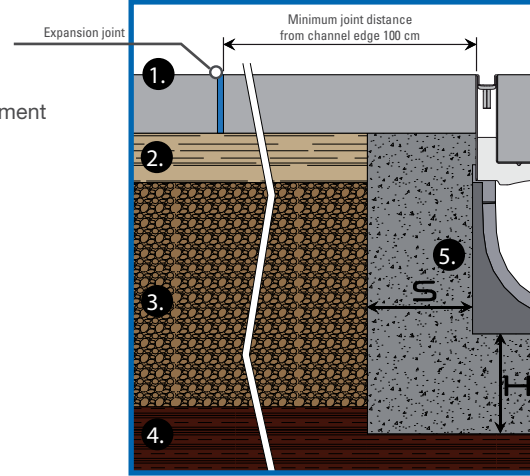

1. Flooring
2. Lower bed layer
3. Bearing layer
4. Subfloor
5. Concrete reinforcement layer
6. Expansion joint

## Case 3 Asphalt (A15-B125-C250)

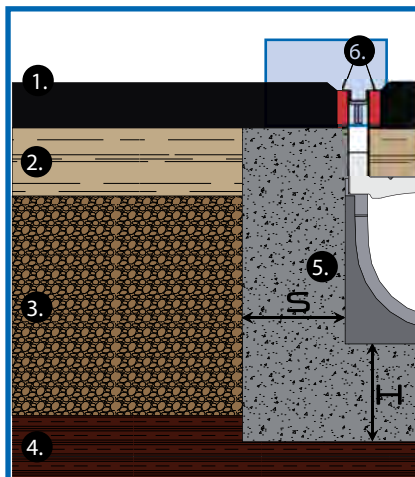

1. Flooring
2. Lower bed layer
3. Bearing layer
4. Subfloor
5. Concrete reinforcement layer
6. Safety joint (if required)

This Sheet is only aimed to give advice on the installation of channels mod. MufleDrain. In any case, always:

- check the carrying capacity characteristics of the underlying layer
- we recommend using Class S4 concrete (EN 206-1) and stone aggregate with maximum diameter 8 mm.
- comply with the height of the installation surface and the thickness of the prop as specified according to the load classes.

### SUMMARY TABLE

Load class (EN 1433)		A 15	B 125	C 250
Applicable load (EN 1433)	kN	15	125	250
Minimum height H of concrete laying bed	mm	100	100	150
Minimum thickness S of the concrete fl anking	mm	100	100	150
Concrete compression strength class (EN 206-1)		C 20/25	C 25/30	C 25/30
Concrete compression strength class <sup>7</sup> (EN 206-1)		C 30/37 XF4	C 30/37 XF4	C 30/37 XF4

7- If concrete can be affected by frost and thaw cycles.

N.B. MufleSystem srl reserves the right to change the technical characteristics herein specified without prior notice. Said technical characteristics are given for information purposes only and are subject to changes as our products are developed.

N.B. Sizes and weights are subject to usual manufacturing tolerance values.

# smart

## The system:

- it supports 2 load classes (B125, C250) in compliance with Standard EN 1433
- it is made up of a HD-PE channel with a strengthening frame
- it is very compact, since the frame is perfectly anchored to the channel body. The frame is made from materials able to resist corrosion due to contact with the surrounding environment and the gratings. The anchoring system was designed to withstand any deformation due shearing or torsional stress
- it is wearproof and very solid thanks to the frame, which ensures a 2.5 mm - thick drive-over edge and a 1.2 mm - thick contact surface
- since the edge shows the exact dimensions for the paving, easy and accurate installation is ensured
- it comprises 3 different types of gratings (with slots, square mesh, anti-heel mesh) made from galvanised steel, stainless steel and ductile cast-iron
- it comes equipped with a classic tie-rod fixing system and a convenient drain gate
- it is ideal for private car parks, footways, canalisation systems in roads and parking areas, transversal canalisation systems (road crossings) with low - speed vehicular traffic (max 15 km/h – in this case the system can support D400 - class gratings, although not in compliance with Standard EN 1433)
- it includes models with small sizes (H 55 and H 80) which are perfect for installation into covered industrial pavings whenever the channel edge needs to be protected during polishing
- it comes complete with drain gullies with siphon
- the range is made up of 8 channels with 3 widths and 4 heights (100/55, 100/80, 100/100, 100/160, 150/100, 150/160, 200/100, 200/160, 200/250)





## “For all the drainage channels the manufacturer shall supply written instructions for general installation” (Ref. § 7.17 EN 1433)

The installation instructions enclosed in the present technical section are given only as an example in order to supply the main guide lines to the final fitter.

Any particular installation must be evaluated/ agreed between MufleSystem srl and the project maker.

The correct installation is necessary to guarantee the proper loads resistance of the drainage system (channel and grating) to static and dynamical traffic which is subjected to.

The correct installation involves a longer operational length of the drainage system itself as well as its better hydraulic function.

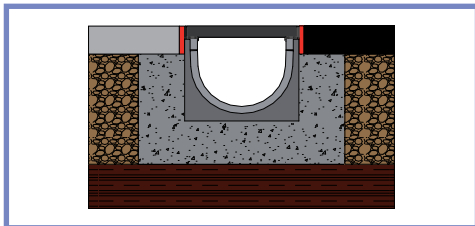
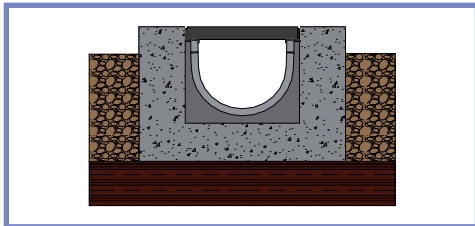
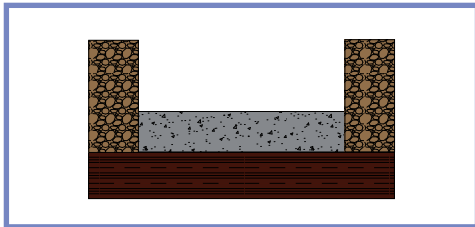
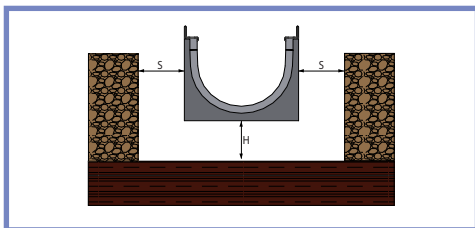

**NEW FEATURE:**  
The channels can be installed with preassembled gratings.

### Step 1

#### HOLE SIZE

The hole needed to lay the MufleDrain channel must allow not only for the size of the channel and the drain piping but also for adequate space for the base H and the side concrete props S. The dimensions to be followed are shown in the Summary Table. In this step make sure the underlying layer is suitable to the load it is expected to support.

### Step 2

#### CONCRETE BASE

Cast the concrete base H up to the height specified, allowing for any inclination in the drainage line. In case that cycles of loading and unloading are often (for example: periodic transit of vehicles) or the loads are particular heavy (E600 - F900), we recommended to reinforce the concrete base with a electro-welded net or with or beaded mouldings Ø 8 with mesh 15x15 cm. At this stage it is needed to arrange possible slopes of the drainage line.

### Step 3

#### CHANNEL ARRANGEMENT

Lay the channels starting from the flow outlet and block them at basis in order to avoid any floating or misalignment during the concrete casting for the side prop.

Allow for the drains required and build the side prop S up to the maximum height allowed by the final coating. Shape it according to the needs based on the drawing. Introduce and fix the grating required beforehand in order to prevent any deformation of the channel due to the thrust of concrete and to speed up installation.

As well as the step 2, also for the side prop concrete arrange the reinforcement.

### Step 4

#### FINAL COATING

When applying the final coating, make sure its upper profile reaches up to minimum 3/5 mm above the grating's flow plane.

## Recommendations for installation

1. In case that channels watertightness is requested, MufleSystem is purposely recommending the use of a bituminous silicone sealant “SHELL TIXOPHALTE”: after carrying out the side prop, apply a thin and homogeneous sealant strip on each slot between the channels and the following one (clean the eventual exceeding sealant). It is strongly advised not to apply the strips of “SHELL TIXOPHALTE” inside the slots in the female joint of the channels before coupling them. Eventually a through and long- lasting guarantees to avoid any leakages can be obtained by welding the joints; this requires welding machines and experienced technicians.
2. While carrying out the phase 2 and 3, protect the gratings with a PVC film so that no final cleaning must be carried out to remove any concrete residues.
3. In case the drainage line is subjected to horizontal loads (for example concrete casting for industrial paving, private car parks and parking decks), it is necessary to arrange effective expansion joints for both direction, parallel and perpendicular to the channels. These joints shall be placed according to the norm standards in force and shall not be placed close to drainage line.
4. In case the drainage line shall be installed on roofs or terraces, it is obligatory to arrange a waterproof sheet according to specific projects.



N.B. MufleSystem srl reserves the right to change the technical characteristics herein specified without prior notice. Said technical characteristics are given for information purposes only and are subject to changes as our products are developed.



# INSTALLATION

smart

## Case 1

Flooring  
(A15-B125-C250-D400<sup>14</sup>)

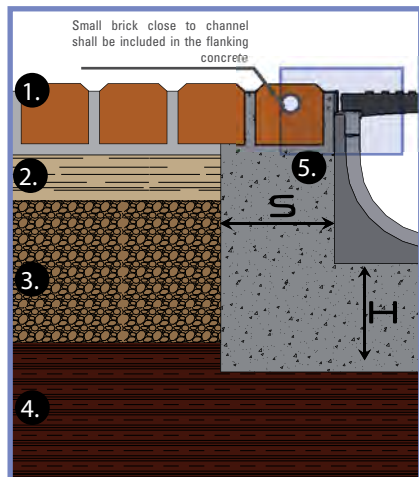

1. Flooring
2. Lower bed layer
3. Bearing layer
4. Subfloor
5. Concrete reinforcement layer

## Case 2

Concrete flooring  
(A15-B125-C250-D400<sup>14</sup>)

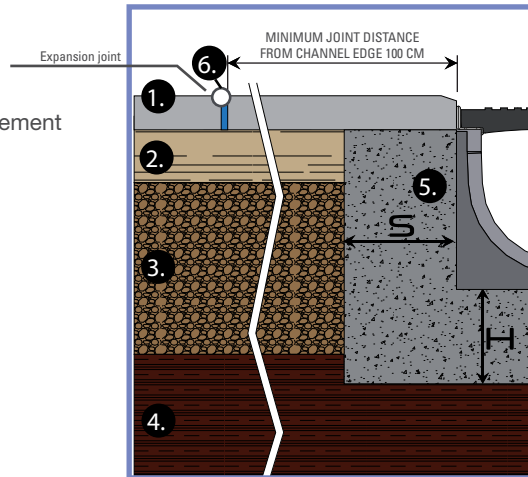

1. Flooring
2. Lower bed layer
3. Bearing layer
4. Subfloor
5. Concrete reinforcement layer
6. Expansion joint

## Case 3

Asphalt  
(A15-B125-C250-D400<sup>14</sup>)

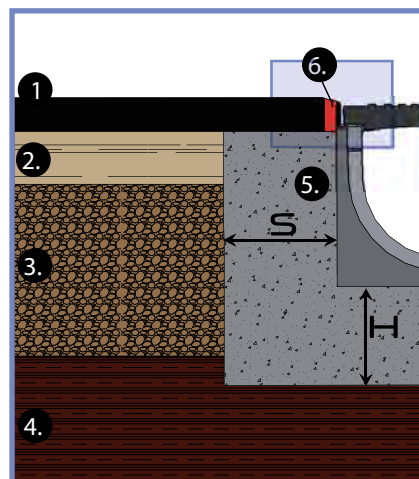

1. Flooring
2. Lower bed layer
3. Bearing layer
4. Subfloor
5. Concrete reinforcement layer
6. Safety joint (if required)

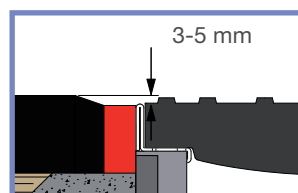

This Sheet is only aimed to give advice on the installation of channels mod. MufleDrain. In any case, always:

- check the carrying capacity characteristics of the underlying layer
- we recommend using Class S4 concrete (EN 206-1) and stone aggregate with maximum diameter 8 mm.
- comply with the height of the installation surface and the thickness of the prop as specified according to the load classes.

### SUMMARY TABLE

Load class (EN 1433)		A 15	B 125	C 250	D 400 <sup>14</sup>
Applicable load (EN 1433)	kN	15	125	250	400
Minimum height H of concrete laying bed	mm	100	100	150	200
Minimum thickness S of the concrete flanking	mm	100	100	150	200
Concrete compression strength class (EN 206-1)		C 20/25	C 25/30	C 25/30	C 25/30
Concrete compression strength class <sup>7</sup> (EN 206-1)		C 30/37 XF4	C 30/37 XF4	C 30/37 XF4	C 30/37 XF4

7- If concrete can be affected by frost and thaw cycles.

14- The grating unit made up of the SMART channel with the grating in class D400 does not comply with Standard EN 1433.

N.B. MufleSystem srl reserves the right to change the technical characteristics herein specified without prior notice. Said technical characteristics are given for information purposes only and are subject to changes as our products are developed.

N.B. Sizes and weights are subject to usual manufacturing tolerance values.

# SLOPE

NEW

## News

The system:

- it supports 4 load classes (C250, D400, E600, F900) in compliance with Standard EN 1433
- it is made up of a HD-PE channel with a strengthening frame
- it is very compact, since the frame is perfectly anchored to the channel body. The frame is made from materials able to resist corrosion due to contact with the surrounding environment and the gratings. The anchoring system was designed to withstand any deformation due shearing or torsional stress
- it is wearproof and very solid thanks to the frame, which ensures a 2.5 mm - thick drive-over edge and a 1.2 mm - thick contact surface
- easy and accurate installation is ensured
- it comprises 3 different types of gratings (with slots, anti-heel mesh, square mesh,) made from galvanised steel, stainless steel and ductile cast-iron.
- the fixing system for the grating is guaranteed by the innovative system hook- lock, in addition the fixing system through the kit tie rods is necessary for the E600 grating
- for a better anchoring between concrete and channel a kit 8 clamps is available on request
- it comes equipped with a classic tie-rod fixing system and a convenient drain gate available in two versions Ø 100 e Ø 110
- it is ideal for private car parks, footways, canalisation systems in roads and parking areas, road crossings with moderate speed vehicular traffic
- it includes models with small sizes (H 55 and H 80) which are perfect for installation into covered industrial pavings whenever the channel edge needs to be protected during polishing
- it comes complete with drain gullies with siphon
- the range is made up of 9 channels with 3 widths and 5 heights (100/55, 100/80, 100/100, 100/160, 150/100, 150/160, 200/100, 200/160, 200/250)



The product must be laid according to MufleSystem's specifications.



# INSTALLATION

**SLOPE**

## “For all the drainage channels the manufacturer shall supply written instructions for general installation” (Ref. § 7.17 EN 1433)

The installation instructions enclosed in the present technical section are given only as an example in order to supply the main guide lines to the final fitter.

Any particular installation must be evaluated/ agreed between MufleSystem srl and the project maker.

The correct installation is necessary to guarantee the proper loads resistance of the drainage system (channel and grating) to static and dynamical traffic which is subjected to.

The correct installation involves a longer operational length of the drainage system itself as well as its better hydraulic function.

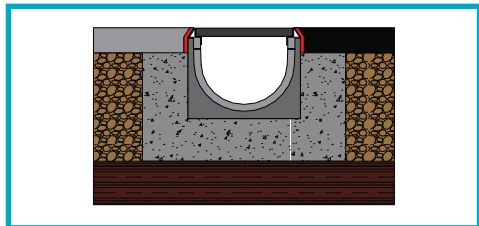
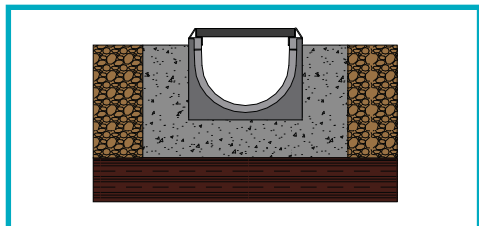
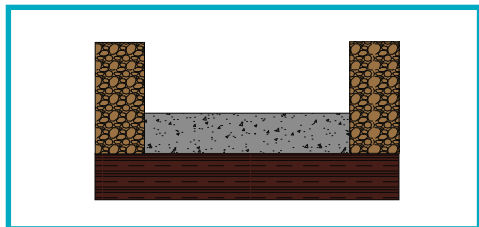
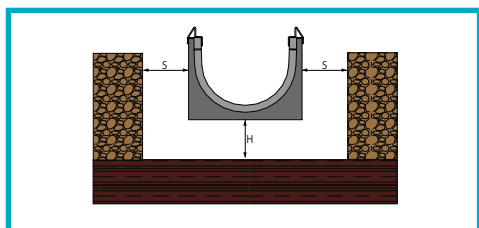

**NEW FEATURE:**  
The channels can be installed with preassembled gratings

### Step 1

#### HOLE SIZE

The hole needed to lay the MufleDrain channel must allow not only for the size of the channel and the drain piping but also for adequate space for the base H and the side concrete props S. The dimensions to be followed are shown in the Summary Table. In this step make sure the underlying layer is suitable to the load it is expected to support.

### Step 2

#### CONCRETE BASE

Cast the concrete base H up to the height specified, allowing for any inclination in the drainage line. In case that cycles of loading and unloading are often (for example: periodic transit of vehicles) or the loads are particular heavy (E600 - F900), we recommended to reinforce the concrete base with a electro-welded net or with or beaded mouldings Ø 8 with mesh 15x15 cm. At this stage it is needed to arrange possible slopes of the drainage line.

### Step 3

#### CHANNEL ARRANGEMENT

Lay the channels starting from the flow outlet and block them at basis in order to avoid any floating or misalignment during the concrete casting for the side prop.

Allow for the drains required and build the side prop S up to the maximum height allowed by the final coating. Shape it according to the needs based on the drawing. Introduce and fix the grating required beforehand in order to prevent any deformation of the channel due to the thrust of concrete and to speed up installation.

As well as the step 2, also for the side prop concrete arrange the reinforcement.

### Step 4

#### FINAL COATING

When applying the final coating, make sure its upper profile reaches up to minimum 3/5 mm above the grating's flow plane.

## Recommendations for installation

1. In case that channels watertightness is requested, MufleSystem is purposely recommending the use of a bituminous silicone sealant “SHELL TIXOPHALTE”: after carrying out the side prop, apply a thin and homogeneous sealant strip on each slot between the channels and the following one (clean the eventual exceeding sealant). It is strongly advised not to apply the strips of “SHELL TIXOPHALTE” inside the slots in the female joint of the channels before coupling them. Eventually a through and long- lasting guarantees to avoid any leakages can be obtained by welding the joints; this requires welding machines and experienced technicians.
2. While carrying out the phase 2 and 3, protect the gratings with a PVC film so that no final cleaning must be carried out to remove any concrete residues.
3. In case the drainage line is subjected to horizontal loads (for example concrete casting for industrial paving, private car parks and parking decks), it is necessary to arrange effective expansion joints for both direction, parallel and perpendicular to the channels. These joints shall be placed according to the norm standards in force and shall not be placed close to drainage line.
4. In case the drainage line shall be installed on roofs or terraces, it is obligatory to arrange a waterproof sheet according to specific projects.



N.B. MufleSystem srl reserves the right to change the technical characteristics herein specified without prior notice. Said technical characteristics are given for information purposes only and are subject to changes as our products are developed.





# INSTALLATION

**SLOPE**

## Case 1

Asphalt  
(C250)

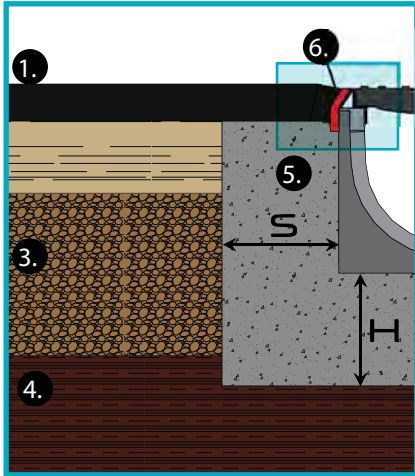

1. Sheet asphalt
2. Lower layer
3. Bearing layer
4. Subfloor
5. Concrete reinforcement layer
6. Bitumen joint

## Case 2

Asphalt  
(D400)

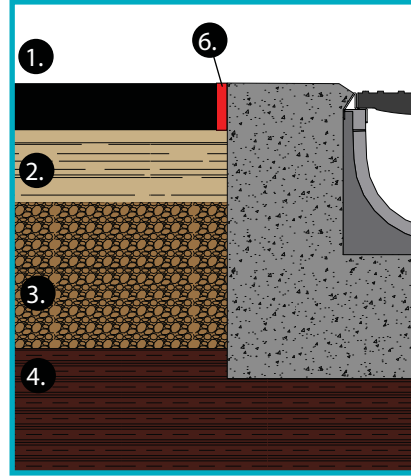

1. Sheet asphalt
2. Lower layer
3. Bearing layer
4. Subfloor
5. Concrete reinforcement layer
6. Bitumen joint

## Case 3

Concrete screed for streets and roads  
(da C250 a D400)

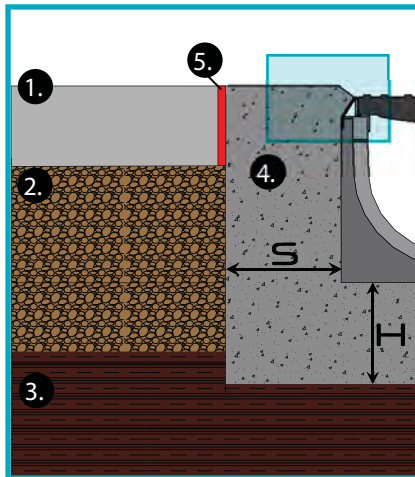

1. Concrete flooring
2. Bearing layer
3. Subfloor
4. Concrete reinforcement layer
5. Expanded joint

## Case 4

Flooring  
(C250)

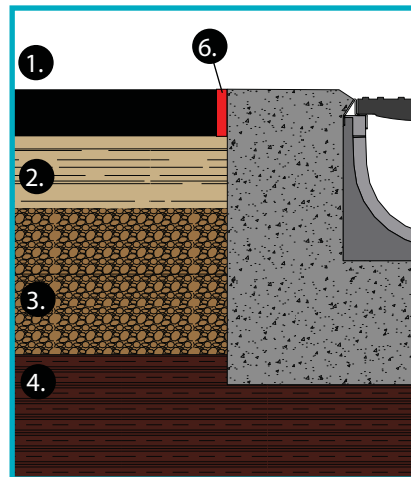

1. Flooring
2. Lower layer
3. Bearing layer
4. Subfloor
5. Concrete reinforcement layer

This Sheet is only aimed to give advice on the installation of channels mod. MufleDrain. In any case, always:

- check the carrying capacity characteristics of the underlying layer
- use class S4 (EN 206-1) and stone aggregate with maximum diameter 8mm.
- comply with the height of the installation surface and the thickness of the prop as specified according to the load classes.

### SUMMARY TABLE

Load class (EN 1433)		C 250	D 400	E 600
Applicable load (EN 1433)	kN	250	400	600
Minimum height H of concrete laying bed	mm	150	200	200
Minimum thickness S of the concrete fl anking	mm	150	200	200
Concrete compression strength class (EN 206-1)		C 25/30	C 25/30	C 30/37
Concrete compression strength class <sup>7</sup> (EN 206-1)		C 30/37 XF4	C 30/37 XF4	C 35/45 XF4

7- If concrete can be affected by frost and thaw cycles.

N.B. Muflesystem reserves the right to modify the technical characteristics on this document without prior notice, these are only informative data that can be changed in the development of our products range.

N.B. Sizes and weights are subject to usual manufacturing tolerance values.

# WING

## The system:

- it supports 4 load classes (C250, D400, E600, F900) in compliance with Standard EN 1433
- it is made up of a HD-PE channel with a strengthening frame
- it is very compact, since the frame is perfectly anchored to the channel body. The frame is made from materials able to resist corrosion due to contact with the surrounding environment and the gratings. The anchoring system was designed to withstand any deformation due shearing or torsional stress
- it is wearproof and very solid thanks to the frame, which ensures a 4 mm - thick drive-over edge and a 2 mm - thick contact surface in compliance with Standard EN 1433 on classes subject to heavy loads
- it comprises a wide range of standard gratings (with slots, square mesh, anti-heel mesh) made from galvanised steel, stainless steel and ductile cast-iron, as well as galvanised-steel and ductile-cast-iron blind covers, and a cover specially designed for composting systems
- it comes complete with an innovative grating for draining asphalt in D400 which has slots in the upper and side sections in order to receive the liquids from the road surface - both surface liquids and liquids absorbed by the draining asphalt
- it has tie-rod and screw fixing systems; and a convenient drain gate
- it is ideal for medium-to-heavy uses, exhibition areas, parking decks, road carriageways, parking areas, service areas, industrial areas, ports and airports, areas where containers are (un)loaded
- it comes complete with drain gullies with siphon
- the range is made up of 11 channels with 3 widths and 6 heights (100/55, 100/80, 100/100, 100/160, 150/40, 150/100, 150/160, 200/40, 200/100, 200/160, 200/250)
- the range is supplemented with the WING channel with ductile-cast-iron strengthening frame - length 1.5 m and usable dimensions 300 x 300 mm. Designed to drain large surfaces





# INSTALLATION



## “For all the drainage channels the manufacturer shall supply written instructions for general installation” (Ref. § 7.17 EN1433)

The installation instructions enclosed in the present technical section are given only as an example in order to supply the main guide lines to the final fitter.

Any particular installation must be evaluated/ agreed between MufleSystem srl and the project maker.

The correct installation is necessary to guarantee the proper loads resistance of the drainage system (channel and grating) to static and dynamical traffic which is subjected to.

The correct installation involves a longer operational length of the drainage system itself as well as its better hydraulic function.

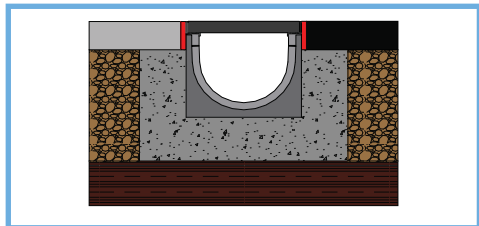
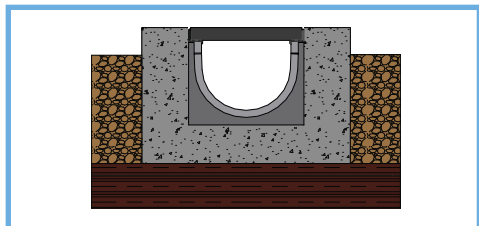
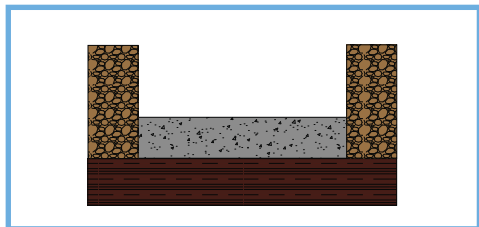
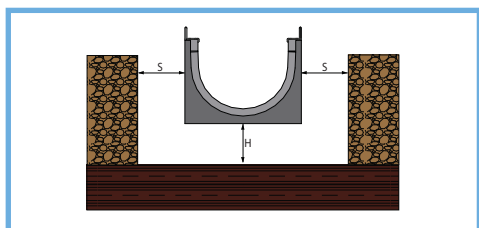

**NEW FEATURE:**  
The channels can be installed with preassembled gratings.

### Step 1

#### HOLE SIZE

The hole needed to lay the MufleDrain channel must allow not only for the size of the channel and the drain piping but also for adequate space for the base H and the side concrete props S. The dimensions to be followed are shown in the Summary Table. In this step make sure the underlying layer is suitable to the load it is expected to support.

### Step 2

#### CONCRETE BASE

Cast the concrete base H up to the height specified, allowing for any inclination in the drainage line. In case that cycles of loading and unloading are often (for example: periodic transit of vehicles) or the loads are particular heavy (E600 - F900), we recommended to reinforce the concrete base with a electro-welded net or with or beaded mouldings Ø 8 with mesh 15x15 cm. At this stage it is needed to arrange possible slopes of the drainage line.

### Step 3

#### CHANNEL ARRANGEMENT

Lay the channels starting from the flow outlet and block them at basis in order to avoid any floating or misalignment during the concrete casting for the side prop.

Allow for the drains required and build the side prop S up to the maximum height allowed by the final coating. Shape it according to the needs based on the drawing. Introduce and fix the grating required beforehand in order to prevent any deformation of the channel due to the thrust of concrete and to speed up installation.

As well as the step 2, also for the side prop concrete arrange the reinforcement.

### Step 4

#### FINAL COATING

When applying the final coating, make sure its upper profile reaches up to minimum 3/5 mm above the grating's flow plane.

## Recommendations for installation

1. In case that channels watertightness is requested, MufleSystem is purposely recommending the use of a bituminous silicone sealant “SHELL TIXOPHALTE”: after carrying out the side prop, apply a thin and homogeneous sealant strip on each slot between the channels and the following one (clean the eventual exceeding sealant). It is strongly advised not to apply the strips of “SHELL TIXOPHALTE” inside the slots in the female joint of the channels before coupling them. Eventually a through and long- lasting guarantees to avoid any leakages can be obtained by welding the joints; this requires welding machines and experienced technicians.
2. While carrying out the phase 2 and 3, protect the gratings with a PVC film so that no final cleaning must be carried out to remove any concrete residues.
3. In case the drainage line is subjected to horizontal loads (for example concrete casting for industrial paving, private car parks and parking decks), it is necessary to arrange effective expansion joints for both direction, parallel and perpendicular to the channels. These joints shall be placed according to the norm standards in force and shall not be placed close to drainage line.
4. In case the drainage line shall be installed on roofs or terraces, it is obligatory to arrange a waterproof sheet according to specific projects.



N.B. MufleSystem srl reserves the right to change the technical characteristics herein specified without prior notice. Said technical characteristics are given for information purposes only and are subject to changes as our products are developed



# INSTALLATION



## Case 1

Asphalt  
(C250)

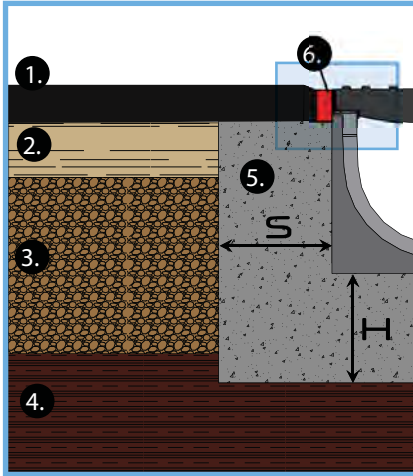

1. Sheet asphalt
2. Lower layer (binder)
3. Bearing layer
4. Subfloor
5. Concrete reinforcement layer
6. Bitumen joint

## Case 2

Asphalt  
(D400-E600-F900)

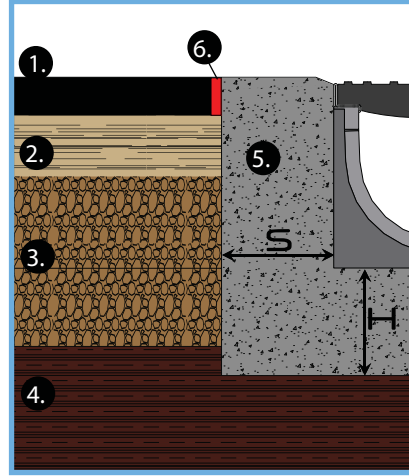

1. Sheet asphalt
2. Lower layer (binder)
3. Bearing layer
4. Subfloor
5. Concrete reinforcement layer
6. Bitumen joint

## Case 3

Concrete screed for streets and roads  
(from C250 to F900)

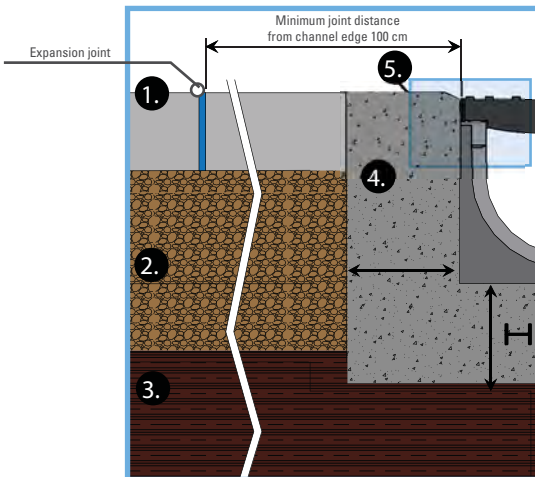

1. Concrete flooring
2. Bearing layer
3. Subfloor
4. Concrete reinforcement layer
5. Bitumen joint

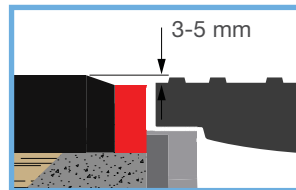

This Sheet is only aimed to give advice on the installation of channels mod. MufleDrain. In any case, always:

- check the carrying capacity characteristics of the underlying layer
- we recommend using Class S4 concrete (EN 206-1) and stone aggregate with maximum diameter 8 mm.
- comply with the height of the installation surface and the thickness of the prop as specified according to the load classes.

## SUMMARY TABLE

Load class (EN 1433)		C 250	D 400	E 600	F 900
Applicable load (EN 1433)	kN	250	400	600	900
Minimum height H of concrete laying bed	mm	150	200	200	250
Minimum thickness S of the concrete flanking	mm	150	200	200	250
Concrete compression strength class (EN 206-1)		C 25/30	C 25/30 <sup>15</sup>	C 30/37	C 35/45
Concrete compression strength class <sup>7</sup> (EN 206-1)		C 30/37 XF4	C 30/37 XF4	C 35/45 XF4	C 40/50 XF4

7- If concrete can be affected by frost and thaw cycles.

15- If installation is in road crossings subject to heavy traffic (especially trucks), Class C30/37 concrete should be used.

N.B. MufleSystem srl reserves the right to change the technical characteristics herein specified without prior notice. Said technical characteristics are given for information purposes only and are subject to changes as our products are developed.

N.B. Sizes and weights are subject to usual manufacturing tolerance values.



# INSTALLATION OF DRAINING ASPHALT GRATING WING 200

WING

**“For all the drainage channels the manufacturer shall supply written instructions for general installation”** (Ref. § 7.17 EN1433)

The installation instructions enclosed in the present technical section are given only as an example in order to supply the main guide lines to the final fitter.

Any particular installation must be evaluated/ agreed between MufleSystem srl and the project maker.

The correct installation is necessary to guarantee the proper loads resistance of the drainage system (channel and grating) to static and dynamical traffic which is subjected to.

The correct installation involves a longer operational length of the drainage system itself as well as its better hydraulic function.

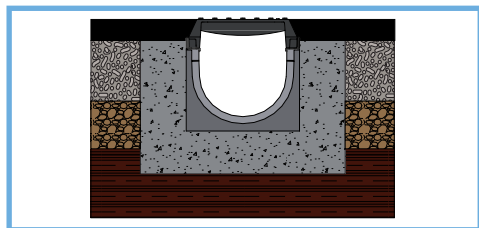
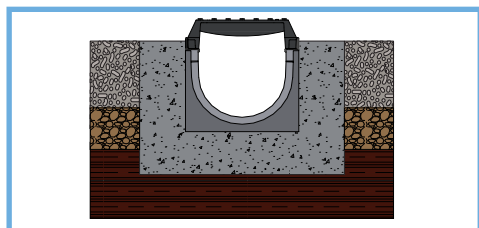
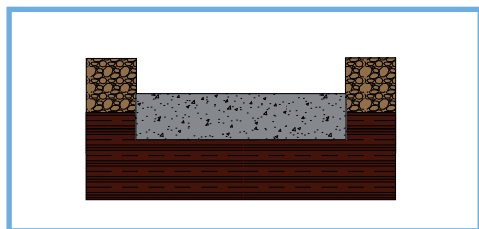
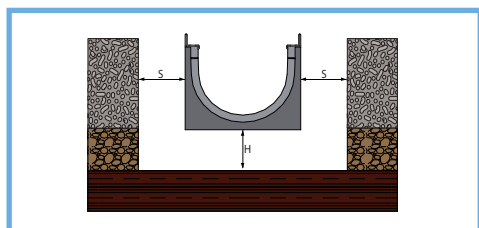

**NEW FEATURE:  
The channels can  
be installed with  
preassembled  
gratings**

## Step 1

### HOLE SIZE

The hole needed to lay the MufleDrain channel must allow not only for the size of the channel and the drain piping but also for adequate space for the base H and the side concrete props S. The dimensions to be followed are shown in the Summary Table. In this step make sure the underlying layer is suitable to the load it is expected to support.

## Step 2

### CONCRETE BASE

Cast the concrete base H up to the height specified, allowing for any inclination in the drainage line. In case that cycles of loading and unloading are often (for example: periodic transit of vehicles) or the loads are particular heavy (E600 - F900), we recommended to reinforce the concrete base with a electro-welded net or with or beaded mouldings Ø 8 with mesh 15x15 cm. At this stage it is needed to arrange possible slopes of the drainage line.

## Step 3

### CHANNEL ARRANGEMENT

Lay the channels starting from the flow outlet and block them at basis in order to avoid any floating or misalignment during the concrete casting for the side prop.

Allow for the drains required and build the side prop S up to the maximum height allowed by the final coating. Shape it according to the needs based on the drawing. Introduce and fix the grating required beforehand in order to prevent any deformation of the channel due to the thrust of concrete and to speed up installation.

As well as the step 2, also for the side prop concrete arrange the reinforcement.

## Step 4

### FINAL COATING

When applying the final coating, make sure its upper profile reaches up to minimum 3/5 mm above the grating's flow plane.

## Recommendations for installation

1. In case that channels watertightness is requested, MufleSystem is purposely recommending the use of a bituminous silicone sealant “SHELL TIXOPHALTE”: after carrying out the side prop, apply a thin and homogeneous sealant strip on each slot between the channels and the following one (clean the eventual exceeding sealant). It is strongly advised not to apply the strips of “SHELL TIXOPHALTE” inside the slots in the female joint of the channels before coupling them. Eventually a through and long- lasting guarantees to avoid any leakages can be obtained by welding the joints; this requires welding machines and experienced technicians.
2. While carrying out the phase 2 and 3, protect the gratings with a PVC film so that no final cleaning must be carried out to remove any concrete residues.
3. In case the drainage line is subjected to horizontal loads (for example concrete casting for industrial paving, private car parks and parking decks), it is necessary to arrange effective expansion joints for both direction, parallel and perpendicular to the channels. These joints shall be placed according to the norm standards in force and shall not be placed close to drainage line.
4. In case the drainage line shall be installed on roofs or terraces, it is obligatory to arrange a waterproof sheet according to specific projects.



N.B. MufleSystem srl reserves the right to change the technical characteristics herein specified without prior notice. Said technical characteristics are given for information purposes only and are subject to changes as our products are developed.



# INSTALLATION OF DRAINING ASPHALT GRATING WING 200

WING

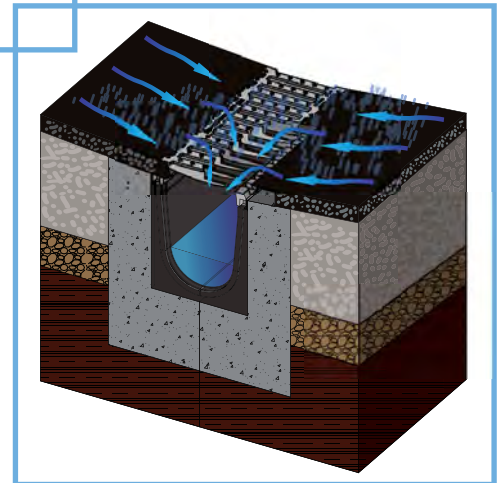
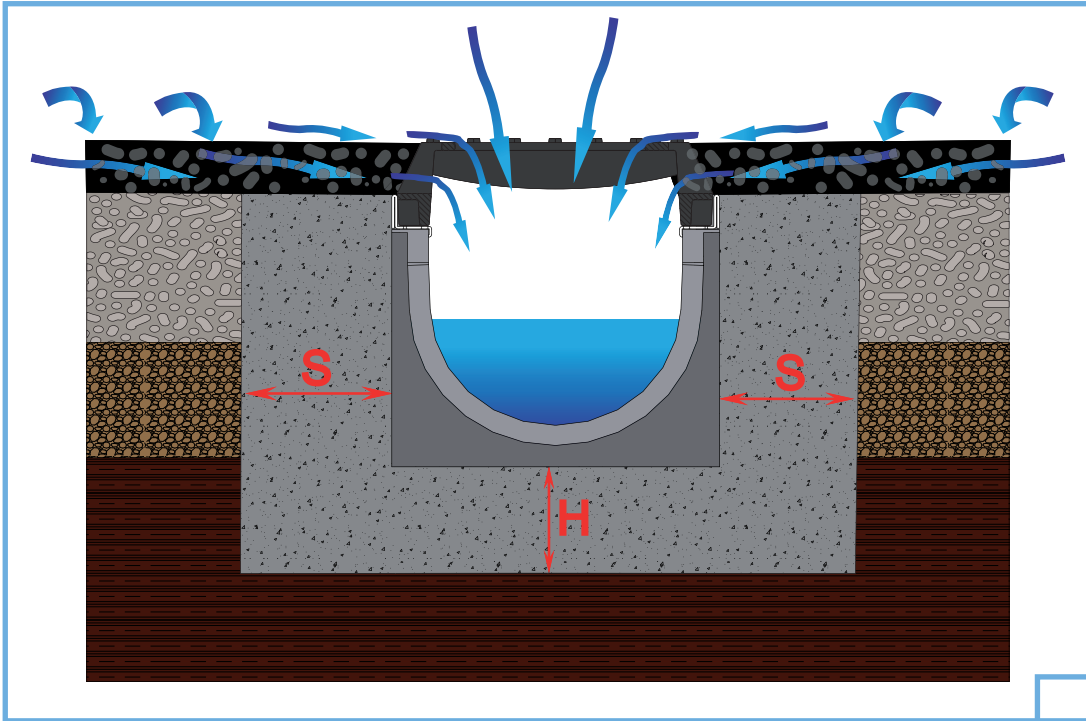

This Sheet is only aimed to give advice on the installation of channels mod. MufleDrain. In any case, always:

- check the carrying capacity characteristics of the underlying layer
- we recommend using Class S4 concrete (EN 206-1) and stone aggregate with maximum diameter 8 mm.
- comply with the height of the installation surface and the thickness of the prop as specified according to the load classes.

## SUMMARY TABLE

Load class (EN 1433)		D 400
Applicable load (EN 1433)	kN	400
Minimum height H of concrete laying bed	mm	200
Minimum thickness S of the concrete fl anking	mm	200
Concrete compression strength class (EN 206-1)		C 25/30 <sup>15</sup>
Concrete compression strength class <sup>7</sup> (EN 206-1)		C 30/37 XF4

7- If concrete can be affected by frost and thaw cycles.

15- If installation is in road crossings subject to heavy traffic (especially trucks), Class C30/37 concrete should be used.

N.B. MufleSystem srl reserves the right to change the technical characteristics herein specified without prior notice. Said technical characteristics are given for information purposes only and are subject to changes as our products are developed.

N.B. Sizes and weights are subject to usual manufacturing tolerance values.



# INSTALLATION OF DRAINING ASPHALT GRATING WING 200

WING

## Case 1

Asphalt  
(from B125 to D400)

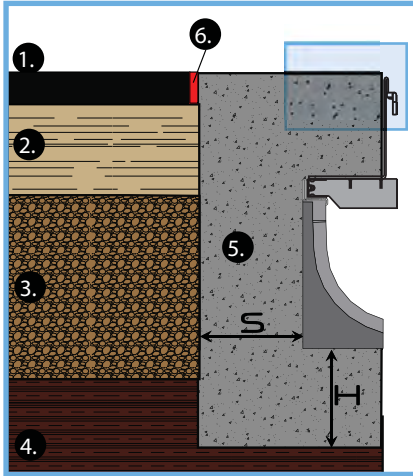

1. Sheet asphalt
2. Strato di allettamento
3. Bearing layer
4. Subfloor
5. Concrete reinforcement layer
6. Safety joint (if required)

## Case 2

Concrete flooring  
(from B125 to D400)

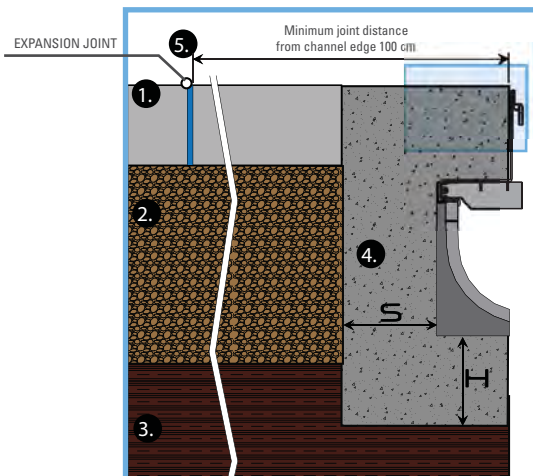

1. Concrete flooring
2. Bearing layer
3. Subfloor
4. Concrete reinforcement layer
5. Expansion joint

This Sheet is only aimed to give advice on the installation of channels mod. MufleDrain. In any case, always:

- check the carrying capacity characteristics of the underlying layer
- we recommend using Class S4 concrete (EN 206-1) and stone aggregate with maximum diameter 8 mm.
- comply with the height of the installation surface and the thickness of the prop as specified according to the load classes.

### SUMMARY TABLE

Load class (EN 1433)		B 125	C 250	D 400
Applicable load (EN 1433)	kN	125	250	400
Minimum height H of concrete laying bed	mm	100	150	200
Minimum thickness S of the concrete flanking	mm	100	150	200
Concrete compression strength class (EN 206-1)		C 25/30	C 25/30	C 25/30 <sup>15</sup>
Concrete compression strength class <sup>7</sup> (EN 206-1)		C 30/37 XF4	C 30/37 XF4	C 30/37 XF4

7- If concrete can be affected by frost and thaw cycles.

15- If installation is in road crossings subject to heavy traffic (especially trucks), Class C30/37 concrete should be used.

N.B. MufleSystem srl reserves the right to change the technical characteristics herein specified without prior notice. Said technical characteristics are given for information purposes only and are subject to changes as our products are developed.

N.B. Sizes and weights are subject to usual manufacturing tolerance values.

# PLUS

## The System:

- it supports 4 load classes (C250, D400, E600, F900) in compliance with Standard EN 1433
- it is made up of a HD-PE channel with a strengthening frame
- it is supplemented with a galvanised or stainless steel en-bloc frame equipped with 8 external clamps (4 each side) for anchoring it to the concrete and 2 spacers ensuring steadiness against torsional deformation
- it is wearproof and very solid thanks to the frame, which ensures a 4 mm - thick drive-over edge and a 2 mm - thick contact surface in compliance with Standard EN 1433 on classes subject to heavy loads
- it comprises a wide range of standard gratings (with slots, square mesh, anti-heel mesh) made from galvanised steel, stainless steel and ductile cast-iron, as well as steel and ductile-cast-iron blind covers, and a cover specially designed for composting systems
- it comes complete with an innovative grating for draining asphalt in D400 which has slots in the upper and side sections in order to receive the liquids from the road surface - both surface liquids and liquids absorbed by the draining asphalt
- it has tie-rod and screw fixing systems; and a convenient drain gate
- it is ideal for heavy uses, road carriageways, road crossings with high-speed vehicular traffic (trucks included), service areas, industrial areas, ports and airports, areas where containers are (un)loaded
- it comes complete with drain gullies with siphon
- the range is made up of 8 channels with 3 widths and 4 heights (100/55, 100/80, 100/100, 100/160, 150/100, 150/160, 200/100, 200/160)

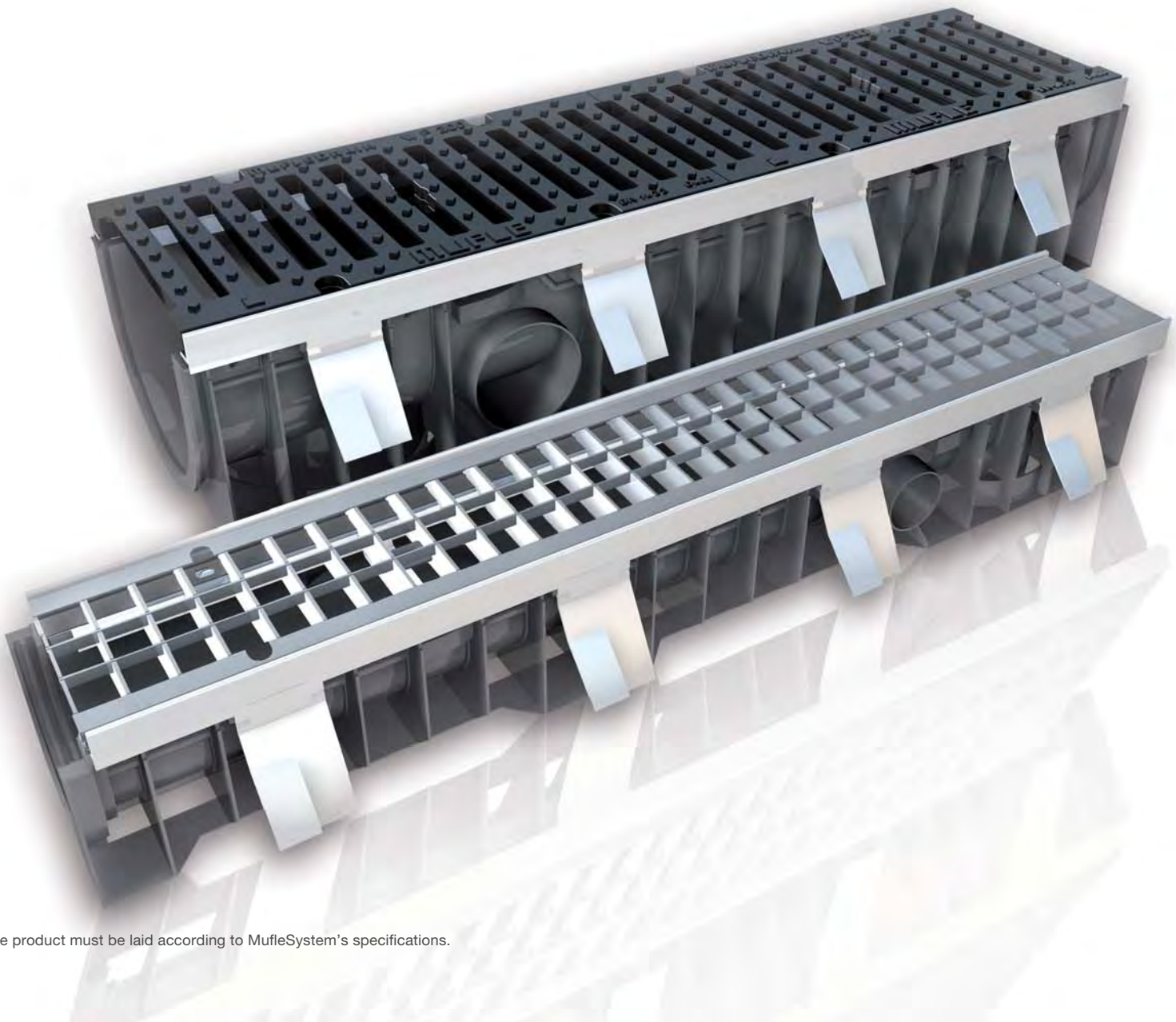

The product must be laid according to MufleSystem's specifications.





# INSTALLATION

# PLUS 200

## “For all the drainage channels the manufacturer shall supply written instructions for general installation” (Ref. § 7.17 EN1433)

The installation instructions enclosed in the present technical section are given only as an example in order to supply the main guide lines to the final fitter.

Any particular installation must be evaluated/ agreed between MufleSystem srl and the project maker.

The correct installation is necessary to guarantee the proper loads resistance of the drainage system (channel and grating) to static and dynamical traffic which is subjected to.

The correct installation involves a longer operational length of the drainage system itself as well as its better hydraulic function.

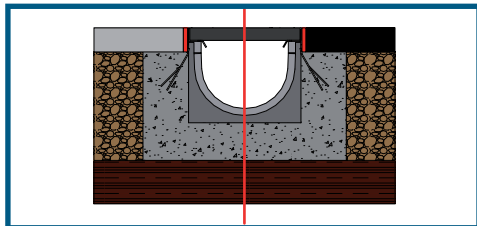
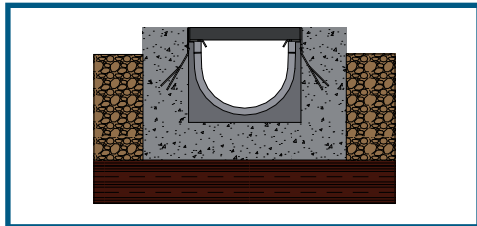
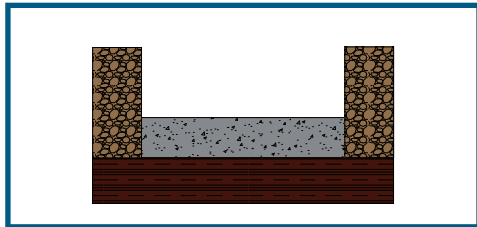
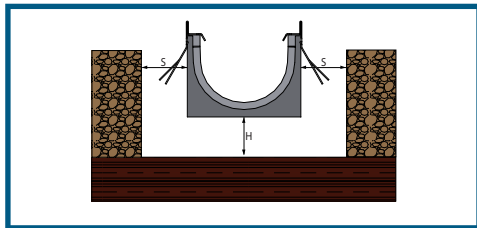

**NEW FEATURE:**  
The channels can be installed with preassembled gratings.

### Step 1

#### HOLE SIZE

The hole needed to lay the MufleDrain channel must allow not only for the size of the channel and the drain piping but also for adequate space for the base H and the side concrete props S. The dimensions to be followed are shown in the Summary Table. In this step make sure the underlying layer is suitable to the load it is expected to support.

### Step 2

#### CONCRETE BASE

Cast the concrete base H up to the height specified, allowing for any inclination in the drainage line. In case that cycles of loading and unloading are often (for example: periodic transit of vehicles) or the loads are particular heavy (E600 - F900), we recommended to reinforce the concrete base with a electro-welded net or with or beaded mouldings Ø 8 with mesh 15x15 cm. At this stage it is needed to arrange possible slopes of the drainage line.

### Step 3

#### CHANNEL ARRANGEMENT

Lay the channels starting from the flow outlet and block them at basis in order to avoid any floating or misalignment during the concrete casting for the side prop.

Allow for the drains required and build the side prop S up to the maximum height allowed by the final coating. Shape it according to the needs based on the drawing. Introduce and fix the grating required beforehand in order to prevent any deformation of the channel due to the thrust of concrete and to speed up installation.

As well as the step 2, also for the side prop concrete arrange the reinforcement.

### Step 4

#### FINAL COATING

When applying the final coating, make sure its upper profile reaches up to minimum 3/5 mm above the grating's flow plane.

## Recommendations for installation

1. In case that channels watertightness is requested, MufleSystem is purposely recommending the use of a bituminous silicone sealant “SHELL TIXOPHALTE”: after carrying out the side prop, apply a thin and homogeneous sealant strip on each slot between the channels and the following one (clean the eventual exceeding sealant). It is strongly advised not to apply the strips of “SHELL TIXOPHALTE” inside the slots in the female joint of the channels before coupling them. Eventually a through and long- lasting guarantees to avoid any leakages can be obtained by welding the joints; this requires welding machines and experienced technicians.
2. While carrying out the phase 2 and 3, protect the gratings with a PVC film so that no final cleaning must be carried out to remove any concrete residues.
3. In case the drainage line is subjected to horizontal loads (for example concrete casting for industrial paving, private car parks and parking decks), it is necessary to arrange effective expansion joints for both direction, parallel and perpendicular to the channels. These joints shall be placed according to the norm standards in force and shall not be placed close to drainage line.
4. In case the drainage line shall be installed on roofs or terraces, it is obligatory to arrange a waterproof sheet according to specific projects.



N.B. MufleSystem srl reserves the right to change the technical characteristics herein specified without prior notice. Said technical characteristics are given for information purposes only and are subject to changes as our products are developed



# INSTALLATION

PLUS

## Case 1

Asphalt  
(C250)

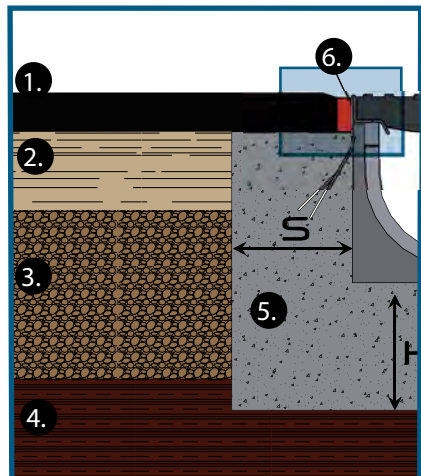

1. Sheet asphalt
2. Lower layer (binder)
3. Bearing layer
4. Subfloor
5. Concrete reinforcement layer
6. Safety joint (if required)

## Case 2

Asphalt  
(D400-E600-F900)

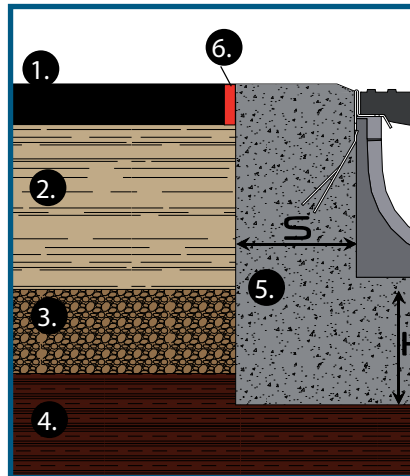

1. Sheet asphalt
2. Lower layer (binder)
3. Bearing layer
4. Subfloor
5. Concrete reinforcement layer
6. Safety joint (if required)

## Case 3

Concrete screed for streets and roads  
(da C250 a F900)

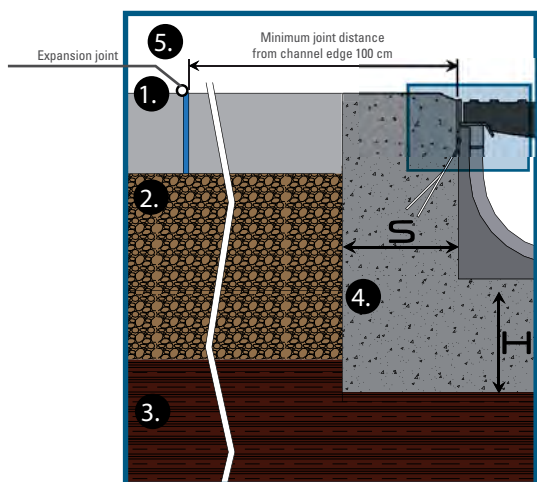

1. Sheet asphalt
2. Strato Inferiore (binder)
3. Bearing layer
4. Subfloor
5. Concrete reinforcement layer
6. Bitumen joint

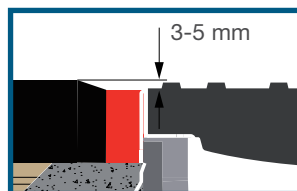

This Sheet is only aimed to give advice on the installation of channels mod. MufleDrain. In any case, always:

- check the carrying capacity characteristics of the underlying layer
- we recommend using Class S4 concrete (EN 206-1) and stone aggregate with maximum diameter 8 mm.
- comply with the height of the installation surface and the thickness of the prop as specified according to the load classes.

## SUMMARY TABLE

Load class (EN 1433)		C 250	D 400	E 600	F 900
Applicable load (EN 1433)	kN	250	400	600	900
Minimum height H of concrete laying bed	mm	150	200	200	250
Minimum thickness S of the concrete flanking	mm	150	200	200	250
Concrete compression strength class (EN 206-1)		C 25/30	C 25/30 <sup>15</sup>	C 30/37	C 35/45
Concrete compression strength class <sup>7</sup> (EN 206-1)		C 30/37 XF4	C 30/37 XF4	C 35/45 XF4	C 40/50 XF4

7- If concrete can be affected by frost and thaw cycles.

15- If installation is in road crossings subject to heavy traffic (especially trucks), Class C30/37 concrete should be used.

N.B. MufleSystem srl reserves the right to change the technical characteristics herein specified without prior notice. Said technical characteristics are given for information purposes only and are subject to changes as our products are developed.

N.B. Sizes and weights are subject to usual manufacturing tolerance values.



# INSTALLATION OF DRAINING ASPHALT GRATING PLUS 200

PLUS

**“For all the drainage channels the manufacturer shall supply written instructions for general installation”** (Ref. § 7.17 EN1433)

The installation instructions enclosed in the present technical section are given only as an example in order to supply the main guide lines to the final fitter.

Any particular installation must be evaluated/ agreed between MufleSystem srl and the project maker.

The correct installation is necessary to guarantee the proper loads resistance of the drainage system (channel and grating) to static and dynamical traffic which is subjected to.

The correct installation involves a longer operational length of the drainage system itself as well as its better hydraulic function.

## Step 1

### HOLE SIZE

The hole needed to lay the MufleDrain channel must allow not only for the size of the channel and the drain piping but also for adequate space for the base H and the side concrete props S. The dimensions to be followed are shown in the Summary Table. In this step make sure the underlying layer is suitable to the load it is expected to support.

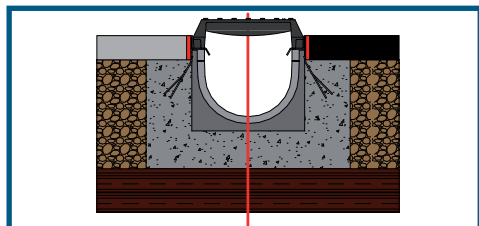
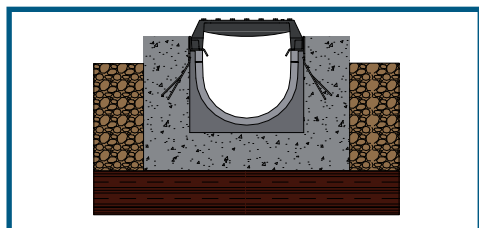
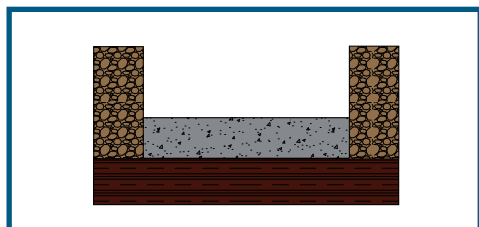
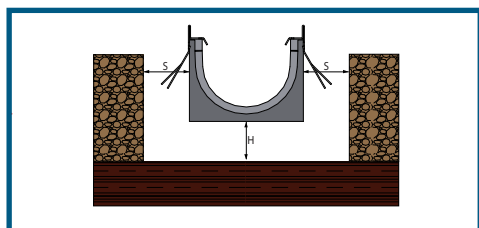

**NEW FEATURE:**  
The channels can be installed with preassembled gratings.

## Step 2

### CONCRETE BASE

Cast the concrete base H up to the height specified, allowing for any inclination in the drainage line. In case that cycles of loading and unloading are often (for example: periodic transit of vehicles) or the loads are particular heavy (E600 - F900), we recommended to reinforce the concrete base with an electro-welded net or with or beaded mouldings Ø 8 with mesh 15x15 cm. At this stage it is needed to arrange possible slopes of the drainage line.

## Step 3

### CHANNEL ARRANGEMENT

Lay the channels starting from the flow outlet and block them at basis in order to avoid any floating or misalignment during the concrete casting for the side prop.

Allow for the drains required and build the side prop S up to the maximum height allowed by the final coating. Shape it according to the needs based on the drawing. Introduce and fix the grating beforehand in order to prevent any deformation of the channel due to the thrust of concrete and to speed up installation.

As well as the step 2, also for the side prop concrete arrange the reinforcement.

## Step 4

### FINAL COATING

When applying the final coating, make sure its upper profile reaches up to minimum 3/5 mm above the grating's flow plane.

## Recommendations for installation

1. In case that channels watertightness is requested, MufleSystem is purposely recommending the use of a bituminous silicone sealant “SHELL TIXOPHALTE”: after carrying out the side prop, apply a thin and homogeneous sealant strip on each slot between the channels and the following one (clean the eventual exceeding sealant). It is strongly advised not to apply the strips of “SHELL TIXOPHALTE” inside the slots in the female joint of the channels before coupling them. Eventually a through and long-lasting guarantee to avoid any leakages can be obtained by welding the joints; this requires welding machines and experienced technicians.
2. While carrying out the phase 2 and 3, protect the gratings with a PVC film so that no final cleaning must be carried out to remove any concrete residues.
3. In case the drainage line is subjected to horizontal loads (for example concrete casting for industrial paving, private car parks and parking decks), it is necessary to arrange effective expansion joints for both direction, parallel and perpendicular to the channels. These joints shall be placed according to the norm standards in force and shall not be placed close to drainage line.
4. In case the drainage line shall be installed on roofs or terraces, it is obligatory to arrange a waterproof sheet according to specific projects.



N.B. MufleSystem srl reserves the right to change the technical characteristics herein specified without prior notice. Said technical characteristics are given for information purposes only and are subject to changes as our products are developed.



# INSTALLATION OF DRAINING ASPHALT GRATING PLUS 200

PLUS

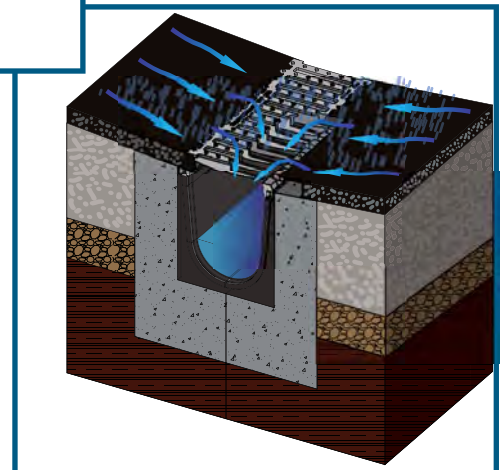
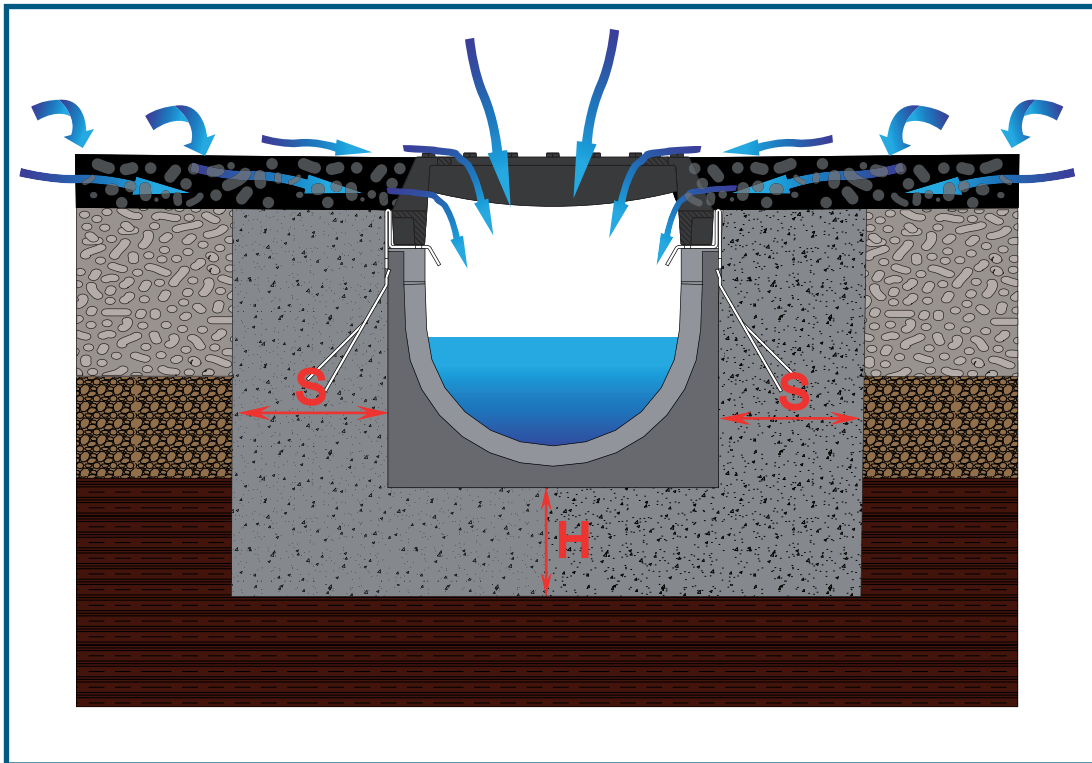

This Sheet is only aimed to give advice on the installation of channels mod. MufleDrain. In any case, always:

- check the carrying capacity characteristics of the underlying layer
- we recommend using Class S4 concrete (EN 206-1) and stone aggregate with maximum diameter 8 mm.
- comply with the height of the installation surface and the thickness of the prop as specified according to the load classes.

## SUMMARY TABLE

Load class (EN 1433)		D 400
Applicable load (EN 1433)	kN	400
Minimum height H of concrete laying bed	mm	200
Minimum thickness S of the concrete fl anking	mm	200
Concrete compression strength class (EN 206-1)		C 25/30 <sup>15</sup>
Concrete compression strength class <sup>7</sup> (EN 206-1)		C 30/37 XF4

7- If concrete can be affected by frost and thaw cycles.

15- If installation is in road crossings subject to heavy traffic (especially trucks), Class C30/37 concrete should be used.  
N.B. Sizes and weights are subject to usual manufacturing tolerance values.

# FUNNEL

# NEW

The "FUNNEL" is a **"high performance"** drainage system where a ductile iron **"grating"** collects rainwater from the surface and, through a ductile iron **"cone"**, conveys it into the HD-PE **"pipe"** with calculated diameter. Pipes are available with external diameter from  $\varnothing 250$  to  $\varnothing 1200$ .

The system guarantees:

- **flexibility and quick installation:** the FUNNEL is supplied with 6 meters long bars. The easy connection among the bars is assured through the coupling and sealing rings.
- **reliability:** the system has been designed according to the standards of the EN 1433.
- **inspections:** it is possible to inspect the system every 50 cm, simply pulling out the gratings.
- **high hydraulic performance:** guarantees the collection and disposal of huge water flows due to a  $\varnothing 110$  outlet every 50 cm.
- is a **patented system.**



The product must be laid according to MufleSystem's specifications.



# INSTALLATION

**FUNNEL**

The following installation instructions and the relative drawings are given only as an example not considering any peculiarities of the installation site, or soil characteristics, or morphology and position of any possible slope. Any particular installation must be suggested by the project maker..

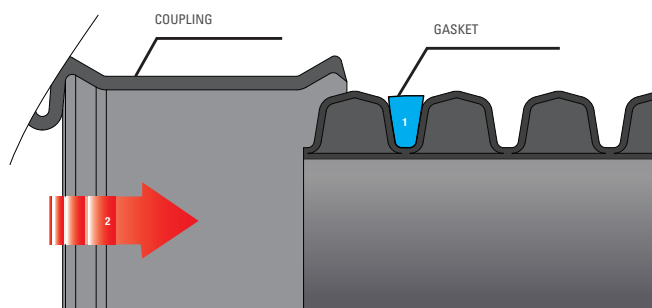

**1 Insert Gasket**  
Insert the gasket in the cavities of the corrugated pipe to be connected to the following one.

**2 Pipes Connection**  
Push constantly and equally on the bars end until the internal seat of the coupling is reached. the lip of the seal will fit bending down the wall and creating a waterproof barrier in case of water leaks.

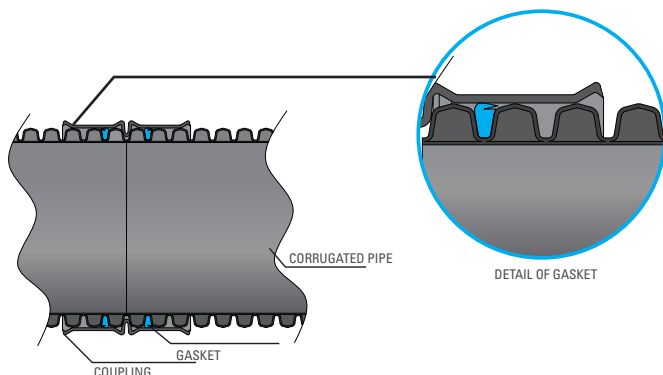

## Step 1

Dig the trench according to the requested dimensions and the right slope indicating.

## Step 2

Cast the concrete bed on the bottom trench of 10/15 cm height at least, realized with particular care.

## Step 3

Lay the pipes (6 meters bars) connecting them through coupling system and a EPDM gasket: the end parts to be connected should be perfectly clean (see the picture on the side).

Pay particular attention to avoiding pipe shocks that could damage it.

## Step 4

Install the "cones" system into the Ø110 holes existing in the pipes and already equipped with a EPDM gasket.

## Step 5

Align and level properly.

## Step 6

To assure the drainage line continuity, the grating are equipped with an overlapping system of an element with the following one. The whole system can be screwed with one single bolt M12 in stainless steel.

## Step 7

Build the flanking around the "cones" using a concrete with an appropriate resistance class according to the load class (from D400 to F900). All technical information necessary for the concrete coating of the flanking are indicated in the table "C". If installation is required, reinforce the base with steel rods during the cast.

## Step 8

Complete the installation according to the requirements or with a road paving (according to specific drawings) or with special paving. The users of the FUNNEL products are responsible for the installation instructions control. For any further information we kindly ask you to contact our technical department.

### Notes

- a) The quotation of the final surface layer should be higher of about 3 mm than the upper grating's profile.
- b) In case of special paving with concrete it is necessary to foresee expansion joints for both directions in order to absorb the horizontal shocks.

Therefore the concrete with Constituency Class S4 (EN 206-1) is recommended and the rock aggregate will have to be made of stones with a maximum diameter of 8 mm. In case of intensive and frequent stressis equip the concrete around the FUNNEL with stretches of electrowelded mesh and/or steel rods.

## SUMMARY TABLE

Load class (EN 1433)		D 400	E 600	F 900
Applicable load (EN 1433)	kN	400	600	900
Minimum height H of concrete laying bed	mm	200	200	250
Minimum thickness S of the concrete fl anking	mm	200	200	250
Concrete compression strength class (EN 206-1)		C 25/30 <sup>15</sup>	C 30/37	C 35/45
Concrete compression strength class <sup>7</sup> (EN 206-1)		C 30/37 XF4	C 35/45 XF4	C 40/50 XF4

7- If concrete can be affected by frost and thaw cycles.

15- If installation is in road crossings subject to heavy traffic (especially trucks), Class C30/37 concrete should be used.

N.B. Sizes and weights are subject to usual manufacturing tolerance values.



# INSTALLATION WITH ONE OUTLET ONLY AT THE END OF DRAINAGE LINE

**FUNNEL**

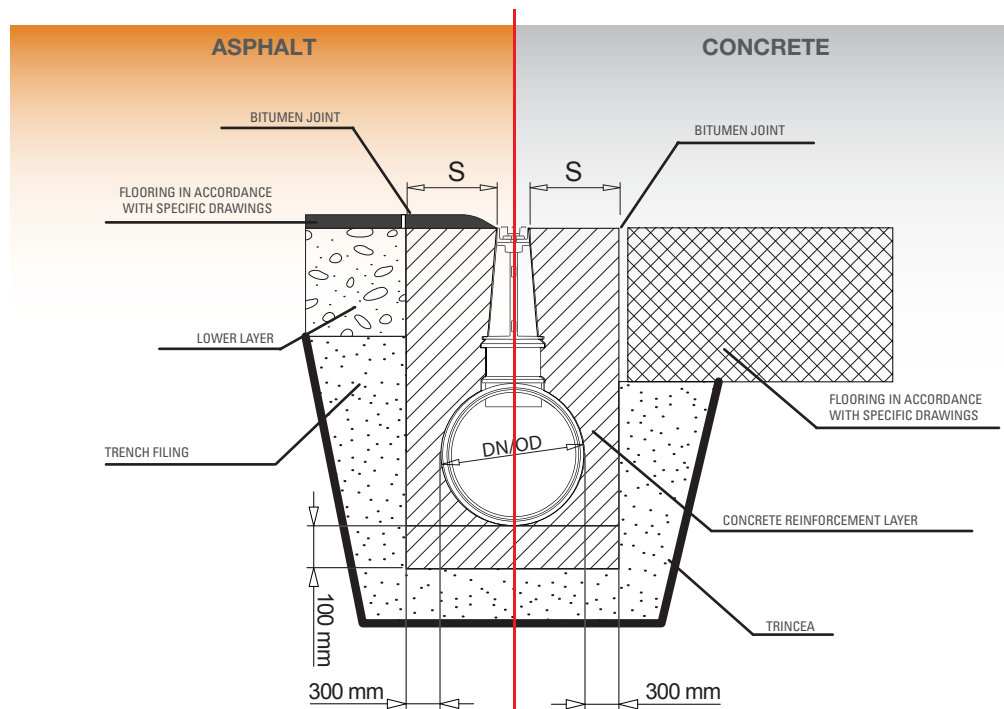
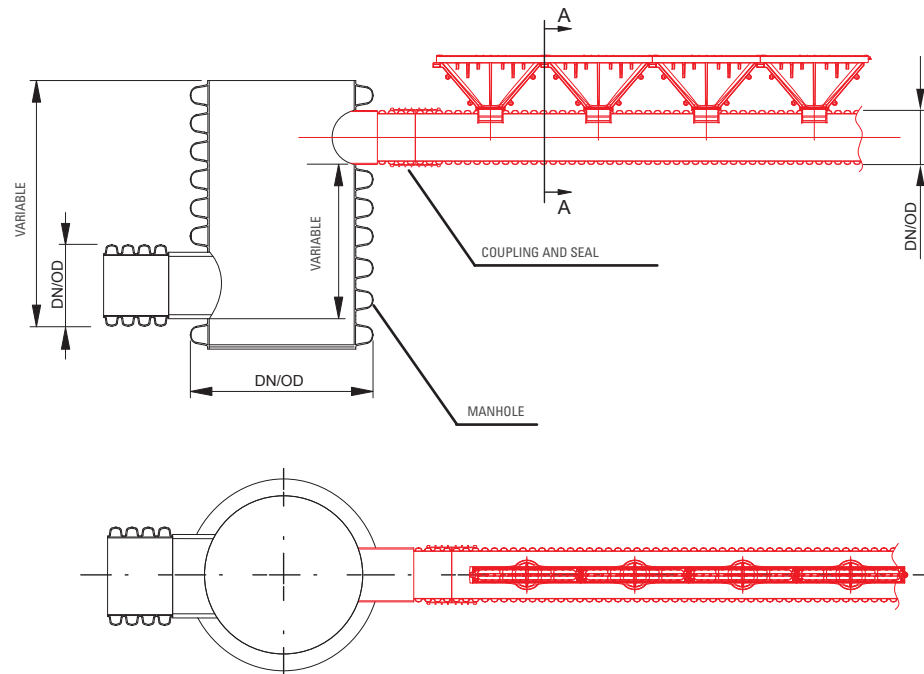

SECTION A-A

N.B. Sizes and weights are subject to usual manufacturing tolerance values.



# INSTALLATION WITH "N" OUTLETS CONNECTED BY PIPE

**FUNNEL**

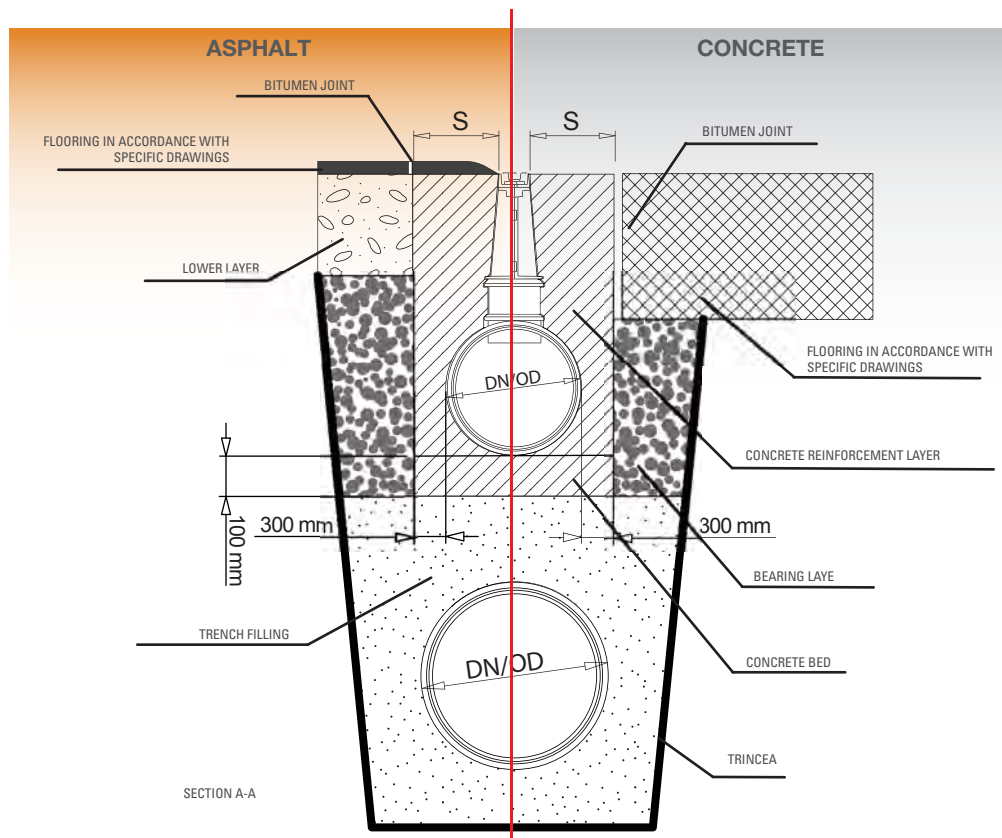
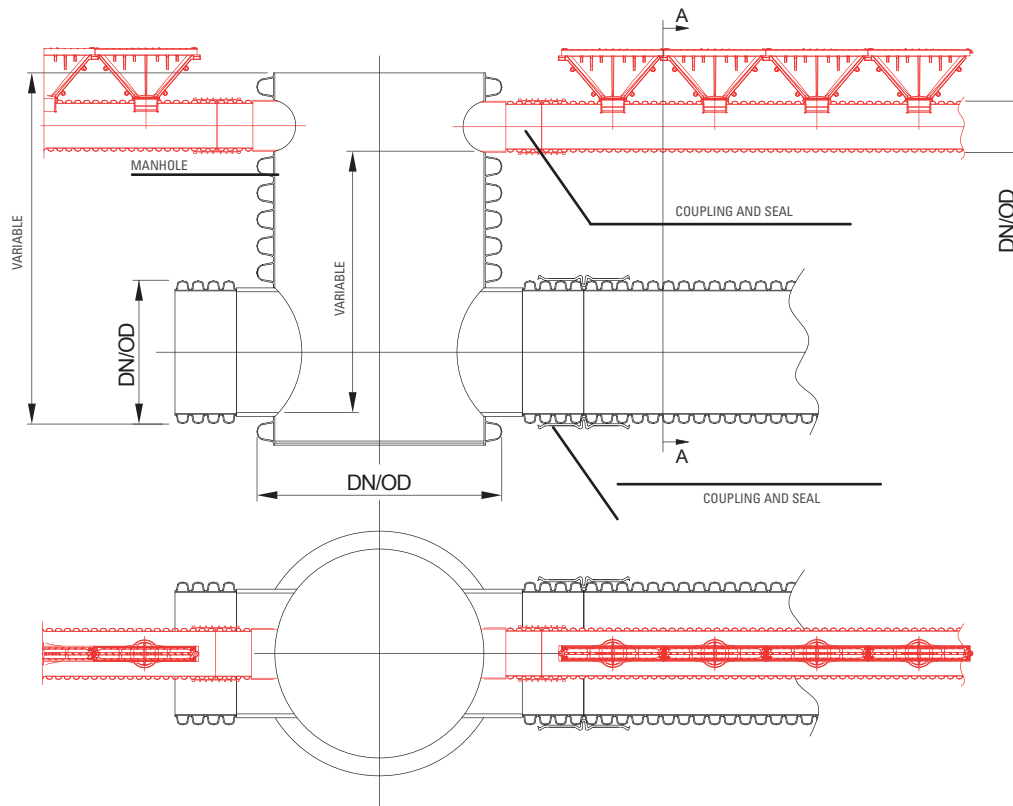

N.B. Sizes and weights are subject to usual manufacturing tolerance values.





# INSTALLATION IN CASE OF $(2S + F) < DN$

**FUNNEL**

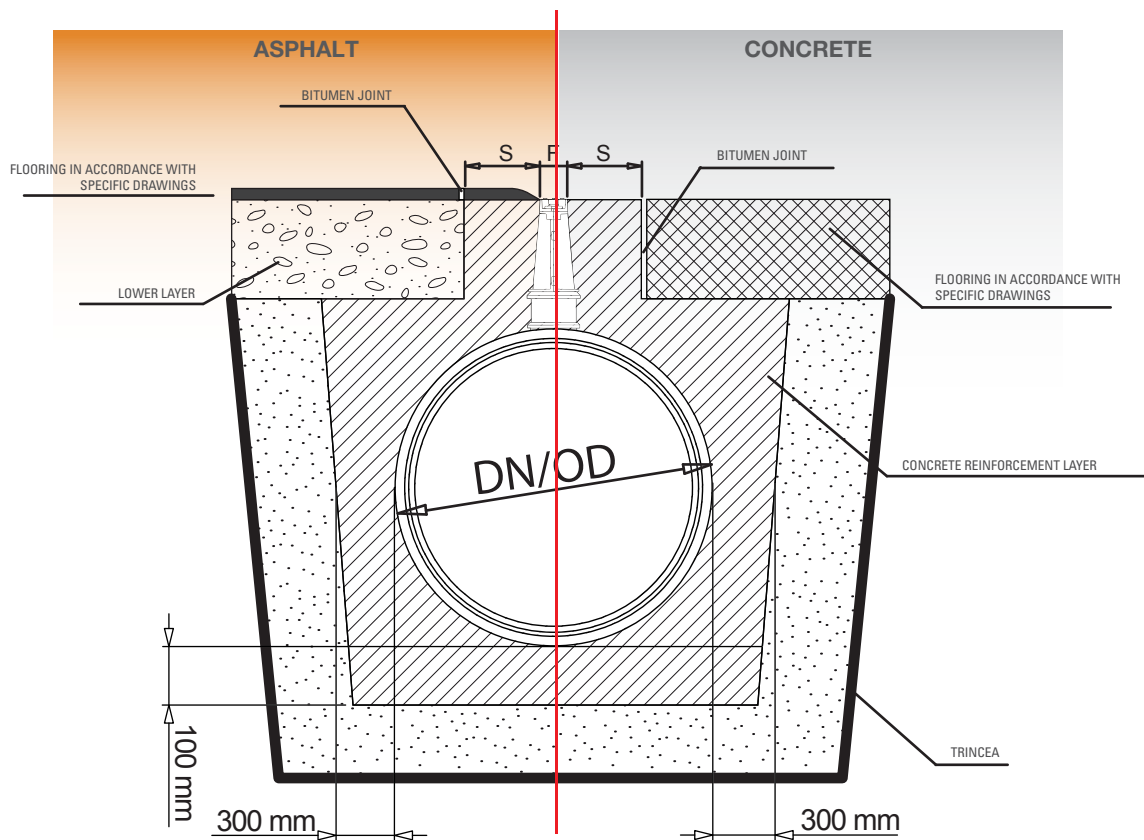

N.B. Sizes and weights are subject to usual manufacturing tolerance values.





**MufleSystem s.r.l.**  
via dell'industria,7  
62017 Porto Recanati - MC  
ITALY

Tel. +39 071 9799122  
Fax +39 071 7592275

info@mufle.com  
www.mufle.com

Numero verde - fax  
**800-234495**  
ONLY FOR ITALY

Certified Company ISO 9001:2008

